



TD-20M

CRAWLER DOZER
STD-LT-LGP

EXTRA



■ **Net Horsepower**
179 kW (240 hp)

■ **Blade Capacity**
up to 8.45 m³ (11.1 yd³)

■ **Operating Weight**
23 650 kg (52,139 lb) STD
24 210 kg (53,373 lb) LT
24 680 kg (54,410 lb) LGP

179 kW (240 hp) Cummins QSC8.3 engine
meets EU Stage IIIA and EPA Tier3 emission standards

Modular cooling system
with hydraulically driven, variable speed
fan improves cooling, fuel and environmental
sound efficiency

Exclusive two-speed geared steering system
offers superior traction

Two-piece hinged radiator guard doors enable
greater access to the cooling fan and cooling
module

Sloped engine hood combined with a high
operator eye level provides excellent
visibility to the blade corners

Semi-U and Full-U blades with tilt or tilt/pitch system,
straight and angle dozer blades with tilt,
to suit any dozing applications

TD-20M Extra Big Perform



Comfortable, sound suppressed cab equipped with:

- air recirculation system
- air conditioner /heater/ pressurizer
- deluxe air suspension seat with arm rests
- ergonomically design joystick controls for direction, blade and ripper

Conveniently placed steps, handholds and walkways greatly assist the operator and provide for a safer work platform

Preset travel speed selection with automatic downshift control provides greater operator efficiency

The modular power train design combined with easily accessible diagnostic check ports, filters and sight gauges provide for excellent serviceability

Exclusive undercarriage design provides maximum durability while giving the operator a smooth, stable ride Standard LTS system and lifetime lubricated rollers and idlers for greatly extended track life

Factory production for arctic, hot climate, landfill, forestry and LGP applications increase this crawler's versatility

Performance, medium size package



Cummins QSC8.3 engine meets EU Stage IIIA and U.S. EPA Tier 3 emissions standards. The QSC advanced electronics provide enhanced engine performance with higher torque and better throttle response at every rpm. Long maintenance intervals, better cold starting and quieter operation provide improved operator comfort.

Exceptional Visibility

Comfortable 6-sided cab with large side and rear sliding windows providing the operator with enhanced view of both the blade and ripper equipment.



Steering Module

Exclusive to Dressta, standard two-speed geared steering allows full power turns for full load retention, lowers sprocket and track bushing wear, increases ripping operation performance and allows greater directional control in both slope work and side cutting.

Two-speed steering provides higher production and lower operating costs day in day out, lowering ownership costs through increased traction and less track slippage.



The new TD-20M Extra crawler dozer offers numerous improvements that provide even greater operational performance and will fulfill every need. Enhanced operator comfort ensures machine productivity along with ease of serviceability.

Power Train System

The modular design incorporates time - proven conventional components that enable fast removal and replacement.

All major components can be replaced in the field in a matter of hours, which drastically reduces machine downtime and provides for the fast return of the machine to profitable operation.

Motion Control

The left hand joystick controls transmission and steering drive for up and down shifting, steering Hi/Lo selection and LH/RH gradual turn.

Preset travel speed selection and auto - downshift provide comfortable operation and high productivity without the need for the operator to concentrate on up or downshifts.



Specification

ENGINE

- * Make and Model CUMMINS QSC8.3
- Type In-line, 6-cylinder
- Aspiration Turbocharged and CAC
- Fuel system HPCR Electronic
- Gross Horsepower, SAE J1995 194 kW (260 hp)
- ** Net Horsepower, SAE J1349/ISO 9249 179 kW (240 hp)
- Rated rpm 2200 rpm
- Max. torque @1500 rpm 1180 Nm (870 lb-ft)
- Displacement 8.3 l (505 in³)
- Bore and Stroke 114 x 135 mm (4.49" x 5.32")
- Air cleaner dry type with exhaust aspirated primary
..... and safety elements and service indicator

* Meets EU Stage IIIA and EPA Tier 3 emission standards

**Net Horsepower at the minimum speed of hydraulic fan 191 kW (256 hp)

TRANSMISSION & TORQUE CONVERTER

Modular, countershaft type power shift, electro-hydraulic control.

Preset travel speed selection and auto-downshift.

Single stage 370 mm (14.6") torque converter with a 2.3:1 stall ratio drives to transmission through a double universal joint.

TRAVEL SPEEDS

Gear	Range	Forward		Reverse	
		km/h	(mph)	km/h	(mph)
1 st	Low	2.9	(1.8)	3.5	(2.2)
	High	3.8	(2.4)	4.5	(2.8)
2 nd	Low	5.3	(3.3)	6.2	(3.9)
	High	6.8	(4.2)	8.0	(5.0)
3 rd	Low	8.3	(5.2)	9.8	(6.1)
	High	10.6	(6.6)	12.5	(7.8)

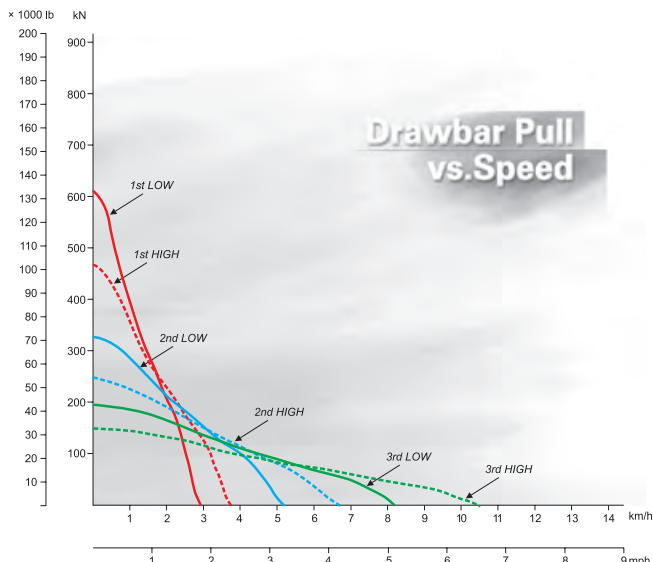

STEERING & BRAKING

Two-speed geared steering module provides gradual turns while maintaining full power to both tracks plus conventional clutch-brake performance for tight or pivot turns. This type of steering system offers superior traction in all types of operations and terrain.

Coupled to 3-speed transmission, the 2-speed steering provides 6 speeds forward and 6 reverse. The left hand joystick controls transmission and steering drive for up and down shifting, steering, Hi/Lo selection and LH/RH gradual geared turn.

Foot pedal applies both brakes for parking and downhill control. Brakes are spring applied and hydraulically released.

FINAL DRIVES

Double-reduction with outboard planetary final drive stage provides desired gear reduction at the sprocket. Ring-type sprocket distributes wear evenly over track bushings letting every tooth ride free one-half of the time to reduce wear. Final drives or sprockets are replaceable without removing track frames.

TRACK FRAME

All-welded heavy box section track frame is kept in alignment with track frame guides providing true vertical oscillation.

- Track rollers, each side STD (LT, LGP) 6 (7)
- Top idlers, each side 2
- Front idlers (drum type) 1
- All rollers and idlers lifespan lubricated
- Oscillation at center of front idler (STD) 295 mm (11.6")
- Oscillation at center of front idler (LT, LGP) 328 mm (12.9")

TRACKS

Lubricated Track System (LTS) virtually eliminates internal pin and bushing wear through use of a patented seal assembly.

The split master link reduces chain removal and installation time.

	STD	LT	LGP
Track shoe width, std.	560 mm (22")	560 mm (22")	864 mm (34")
Track shoes, each side	40	42	42
Ground contact area	3.2 m ² (4,972 in ²)	3.4 m ² (5,324 in ²)	5.3 m ² (8,228 in ²)
Ground pressure (w/standard equipment)	72.4 kPa (10.5 psi)	68.8 kPa (10.0 psi)	45.5 kPa (6.6 psi)
Height of grouser	67 mm (2.63")		
Ground clearance	460 mm (18.1")		

REFILL CAPACITIES

	Liter	(US gal)
Fuel tank	490	(130)
Cooling system	50	(13.2)
Crankcase	23	(6.1)
Transmission system	173	(45.8)
Final drive, each side	38	(10)
Hydraulic reservoir	115	(30.4)

OPERATING WEIGHT

Includes standard equipment and full fuel.

	STD	LT	LGP
Type of blade	Semi-U	Semi-U	Straight
Canopy ROPS	23650 kg (52,139 lb)	24210 kg (53,373 lb)	24680 kg (54,410 lb)
Cab ROPS	24200 kg (53,351 lb)	24760 kg (54,586 lb)	25230 kg (55,622 lb)

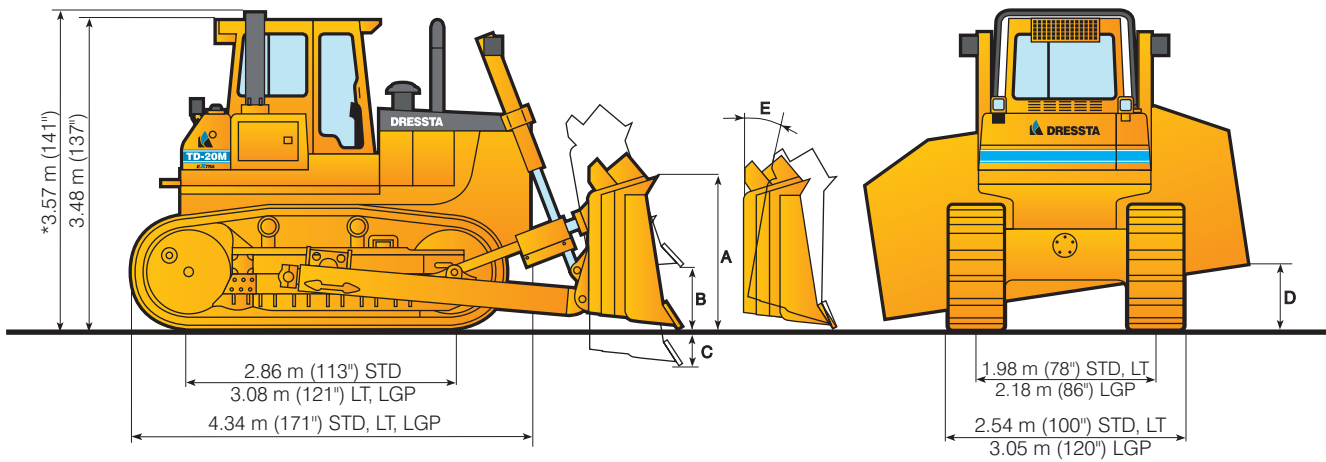

* OVERALL HEIGHT w/Canopy ROPS/FOPS - 3.62m (142.5")
VERTICAL DIMENSIONS INCLUDE 67 mm (2.63") GROUSER HEIGHT

OVERALL DIMENSIONS WITH EQUIPMENT

BLADE SELECTION		SEMI-U	FULL-U	ANGLE	STRAIGHT
Length with blade and drawbar	STD	5.69 m (18'8")	5.93 m (19'5")	5.77 m (18'11")	-
	LT	5.91 m (19'5")	6.15 m (20'2")	5.99 m (19'8")	-
	LGP	-	-	-	5.73 m (18'10")
Length with blade and multi-shank ripper	STD	6.89 m (22'7")	7.13 m (23'5")	6.97 m (22'10")	-
	LT	7.11 m (23'4")	7.35 m (24'1")	7.19 m (23'7")	-
Length with blade and single-shank ripper	STD	7.05 m (23'2")	7.29 m (23'11")	7.13 m (23'5")	-
	LT	7.27 m (23'10")	7.51 m (24'8")	7.35 m (24'1")	-
Width, blade angled		-	-	4.00 m (13'2")	-
Width over trunnions		2.89 m (9'6")	2.89 m (9'6")	2.89 m (9'6")	3.32 m (10'11")
Width over "C" frame		-	-	3.17 m (10'5")	-

BLADE SPECIFICATIONS

BLADE SELECTION		SEMI-U	FULL-U	ANGLE	STRAIGHT
UNDERCARRIAGE		STD & LT	STD & LT	STD & LT	LGP
Blade Capacity, SAE J1265		7.04 m ³ (9.2 yd ³)	8.45 m ³ (11.1 yd ³)	3.88 m ³ (5.1 yd ³)	6.03 m ³ (7.9 yd ³)
Blade dimensions: - width over end bits - height	A	3.5 m (138")	3.86 m (152")	4.41 m (174")	4.37 m (172")
		1.6 m (63")	1.6 m (63")	1.09 m (43")	1.36 m (54")
Max. lift, straight	B	STD 1150 mm (45")	STD 1150 mm (45")	STD 1160 mm (46")	1210 mm (47.6")
		LT 1220 mm (48")	LT 1220 mm (48")	LT 1230 mm (48.4")	
Max. drop below ground level	C	STD 505 mm (19.9")	STD 505 mm (19.9")	STD 615 mm (24.2")	522 mm (20.6")
		LT 532 mm (20.9")	LT 532 mm (20.9")	LT 647 mm (25.5")	
Max. tilt adjustment	D	670 mm (26.3")	720 mm (28.3")	480 mm (19")	660 mm (26")
Blade angle, either side		-	-	25°	-
Max. pitch adjustment	E	10°	10°	-	-
Weight of blade equipment		3420 kg (7,540 lb)	3800 kg (8,377 lb)	3230 kg (7,120 lb)	2756 kg (6,076 lb)

RIPPER SPECIFICATIONS

RIPPER SELECTION	MULTI-SHANK	SINGLE-SHANK
Tool Beam		
Overall width	2130 mm (84")	1383 mm (54")
Cross section (height x width)	305 x 381 mm (12" x 15")	330 x 478 mm (13" x 18.8")
Ground clearance under tool beam:		
	- ripper raised	1295 mm (51")
- ripper lowered	178 mm (7")	100 mm (3.9")
Shanks		
Number of shanks per ripper, max.	3	1
Spacing center to center	991 mm (39")	-
Penetration, max.	700 mm (27.6")	834 mm (32.8")
Ground clearance, max. raised	596 mm (23.5")	538 mm (21.2")
Shank positions (vertical)	2	2
Weight		
Complete, including one shank	2900 kg (6,400 lb)	2845 kg (6,272 lb)
Each additional shank	196 kg (432 lb)	-
Penetration Force	91.1 kN (20,479 lb)	89.99 kN (20,230 lb)
Pryout Force	282.2 kN (63,439 lb)	272.3 kN (61,213 lb)

TD-20M CRAWLER DOZER STD-LT-LGP



HYDRAULIC CONTROL SYSTEM

Multiple gear pumps, driven from torque converter.

Output @ 6.89 MPa (1,000 psi) and 2330 rpm:

1 st pump - 142 l/min (37.5 gpm)

2 nd pump - 62.5 l/min (16.5 gpm)

and pilot pump output @ 2.07 MPa (300psi) - 35.2 l/min (9.3 gpm)

Relief valve setting:

blade lift & ripper 16.9 MPa (2,450 psi)

tilt 17.9 MPa (2,600 psi)

Cylinders, bore and stroke:

lift 110 x 1300 mm (4.33" x 51.18")

tilt 180 x 146.5 mm (7.09" x 5.73")

tilt/pitch 180/165.1 x 146.5 mm (7.09"/6.5" x 5.73")

STANDARD EQUIPMENT

- Air cleaner, dry type, with exhaust aspirated primary, safety elements and service indicator
- Alarm, back-up
- Alternator, 50 A
- Antifreeze, -37°C (-34°F)
- Batteries, (2) 12 V, 815 CCA, maintenance free
- Brakes, foot, spring applied, hydraulically released
- Canopy, 2 post ROPS/FOPS (SAE J1040, J231)
- Coolant filter conditioner
- Cooling module; includes radiator, transmission oil cooler, hydraulic oil/fan drive oil cooler and charge air cooler; isolation mounted
- Decelerator - right foot pedal and brake - center foot pedal
- Diagnostic centers for power train and equipment hydraulic pressures
- Drawbar, rigid
- Ecological drains for engine oil, radiator coolant and hydraulic oil
- Engine hood, solid, sloped
- Engine side doors, hinged, perforated type
- Exhaust pipe extension
- Fan, hydraulically driven, suction type, variable speed
- Filters, engine oil, full flow and by-pass with replaceable "spin-on" elements
- Filters, power train and equipment hydraulics, "spin-on" micro glass type
- Final drive seal guard
- Fuel strainer
- Guards: crankcase, hinged, with front pull hook, transmission, fan, radiator, sprocket rock and dirt deflector
- Hitch retrieval (LGP)
- Horn, electric
- Hydraulic control, 1 valve, 1 lever with pilot operated blade control (lift)
- Instruments:
 - Gauges: fuel level, engine coolant temperature, engine oil pressure, torque converter oil temp., voltmeter, hourmeter, joystick control display
 - Warning lights: air cleaner filter, transmission oil filter, hydraulic oil filter, transmission/clutch oil low pressure
 - Audible & visual warning system: low engine coolant level, low engine oil pressure
- Lights with guards, 2F - lift cylinders mounted, 2R - fuel tank mounted
- Muffler, under engine hood, insulated
- Radiator guard door, two-piece, louvered, hinged
- Rear access platform
- Receptacle, starting/charging
- Seat belt (SAE J386) - 3" wide, retractable
- Seat, air suspension type, vinyl cover, adjustable with arm rests, swivel 14° to right
- Starting, 24 V
- Starting aid - air grid heater
- Steering, planetary type, 2-speed, left hand single lever control (joystick)
- Tools compartment
- Torque converter, single stage
- Transmission, power shift, 3 speeds forward, 3 reverse, combined with 2 speed steering provides 6 speeds forward and 6 reverse, preset travel speed selection and auto-downshift
- UNDERCARRIAGE
 - Track frames, oscillating type, lifespan lubricated rollers and idlers
 - Track adjusters, hydraulic
 - Track chain end guides, integral
 - STANDARD (STD)
 - Track chain, sealed and lubricated (LTS) with split master link, 40 links
 - Track frame, 6 roller, 1981 mm (78") gauge
 - Track shoes, 560 mm (22"), grouser type
 - LONG TRACK (LT)
 - Track chain, sealed and lubricated (LTS) with split master link, 42 links
 - Track chain center guides
 - Track frame, 7 roller, 1981 mm (78") gauge
 - Track shoes, 560 mm (22"), grouser type
 - LOW GROUND PRESSURE (LGP)
 - Track chain, sealed and lubricated (LTS) with split master link, 42 links
 - Track chain center guides
 - Track frame, 7 roller, 2180 mm (86") gauge
 - Track shoes, 864 mm (34"), extreme clipped corner, grouser type
 - Water separator fuel system

OPTIONAL ATTACHMENTS

- AM/FM CD radio
- Batteries, cold start, (2) 12 V, 960 CCA
- Blade Equipment:
 - Full-U, w/tilt or tilt/pitch, 8.45 cu.m (11.1 cu.yd)
 - Semi-U, w/tilt or tilt/pitch, 7.04 cu.m (9.2 cu.yd)
 - Angle dozer, less tilt, 3.88 cu.m (5.1 cu.yd)
 - Straight blade (LGP) w/tilt, 6.03 cu.m (7.9 cu.yd)
 - Hydraulic tilt for Angle dozer
- Cab and ROPS Equipment:
 - Air conditioner/heater/pressurizer/defroster, underseat mounted, A/C condenser behind roof mounted
 - Air recirculation system with MSHA filters
 - Cab w/sound suppression, air recirculation system, 4 wipers w/washers, inside mirror, dome light and tinted safety glass
 - Heater/pressurizer/defroster
 - ROPS for cab and/or forestry attachment
 - Sweeps, forestry, front and rear
 - Screen rear (includes deduct for standard rear access platform)
 - Seat, air suspension, fabric cover (for use w/cab)
 - Sun visor in cab
 - Drawbar, heavy duty, counterweight
 - Engine enclosures: perforated hood and perforated side doors
 - Exhaust extension with guard (for use with forestry sweeps)
 - Guards:
 - Crankcase, severe service w/hook
 - Track roller, full length (LT & LGP)
 - Track roller, full length (STD)
 - Transmission, severe service
 - Tank guard, bolted (includes deduct for rear access platform)
 - Hydraulic controls, 3-spool valve, 2-lever
 - Inspection lamp, 24 V, portable with 6 m (20) cable
 - Instrument panel guard (for use w/Canopy ROPS/FOPS)
 - Lights for Canopy ROPS/FOPS, 2F-2R
 - Lights for cab, 2F-2R
 - Lights, 2F, ROPS mounted, for use w/cab (not for use with sweeps)
 - Lights, 2F, sweeps mounted (instead of standard 2F lift cylinder mounted lights)
 - Mirrors, 2 pcs, exterior
 - Ripper w/o hydraulic pitch, multi-shank beam
 - Hydraulic pitch for ripper beam
 - Ripper shank w/pin, max. 3
 - Ripper w/o hydraulic pitch, single-shank beam
 - Hydraulic pitch for ripper beam
 - Pin puller, hydraulic
 - Ripper shank
 - Screening package; cab for screens installation must be ordered
 - Screens for cab windows (front, rear, side and doors)
 - Screens for tractor and cab lights
 - Starting/charging receptacle plug assembly with 4,6 m (15) cable
 - Track shoes, set of 80, clipped corner (STD) 610 mm (24"), 660 mm (26")
 - Track shoes, set of 84, clipped corner (LT) 610 mm (24"), 660 mm (26")
 - Tools in metal box
 - Vandalism protection

Specifications subject to change without notice. Illustrations and pictures may include optional equipment and may not include all standard equipment.

DRESSTA Co.Ltd.

Kwiatkowskiego 1, 37-450 Stalowa Wola, POLAND
tel. +48 (15) 813 5252, 813 4556 fax: +48 (15) 844 4714
www.dressta.com.pl