

Robex

480LC-9A

With Tier 4 Interim Engine installed

HYUNDAI HEAVY INDUSTRIES

MOVING YOU FURTHER



 **HYUNDAI**

Specifications R480LC-9A

ENGINE

MODEL	CUMMINS QSX11.9	
Type	Water cooled, 4 cycle Diesel, 6-Cylinders in line, direct injection, turbocharged, charged air cooled and low emission	
Rated flywheel horse power		
SAE	J1995 (gross)	372 HP (277 kW) / 1,800 rpm
	J1349 (net)	352 HP (263 kW) / 1,800 rpm
DIN	6271/1 (gross)	377 PS (277 kW) / 1,800 rpm
	6271/1 (net)	357 PS (263 kW) / 1,800 rpm
Max. torque	186.7 kgf.m (1,350 lbf.ft) / 1,400 rpm	
Bore x stroke	130 mm x 150 mm (5.12" x 5.91")	
Piston displacement	11,900 cc (726 in ³)	
Batteries	2 x 12 V x 160 AH	
Starting motor	24 V; 7.2 kW	
Alternator	24 V; 70 Amp	

HYDRAULIC SYSTEM

MAIN PUMP	
Type	Variable displacement tandem-axis piston pumps
Max. flow	2 x 360 l/min (97.7 US gpm / 81.4 UK gpm)
Sub-pump for pilot circuit	Gear pump
Cross-sensing and fuel saving pump system	
HYDRAULIC MOTORS	
Travel	Two-speed axial pistons motor with brake valve and parking brake
Swing	Axial piston motor with automatic brake
RELIEF VALVE SETTING	
Implement circuits	330 kgf/cm ² (4,690 psi)
Travel	330 kgf/cm ² (4,690 psi)
Power boost (boom, arm, bucket)	360 kgf/cm ² (5,120 psi)
Swing circuit	285 kgf/cm ² (4,050 psi)
Pilot circuit	40 kgf/cm ² (570 psi)
Service valve	Installed
HYDRAULIC CYLINDERS	
No. of cylinder-bore x stroke	Boom: 2-170 x 1,570 mm (6.7" x 61.8")
	Arm: 1-190 x 1,820 mm (7.5" x 71.7")
	Bucket: 1-160 x 1,370 mm (6.3" x 53.9")

DRIVES & BRAKES

Drive method	Fully hydrostatic type
Drive motor	Axial piston motor; in-shoe design
Reduction system	Planetary reduction gear
Max. drawbar pull	38,500 kgf (84,800 lbf)
Max. travel speed (high) / (low)	4.8 km/h (3.0 mph) / 3.1 km/h (1.9 mph)
Gradeability	35° (70 %)
Parking brake	Multi wet disc

CONTROL

Pilot pressure operated joysticks and pedals with detachable lever provide almost effortless and fatigueless operation.

Pilot control	Two joysticks with one safety lever (LH): Swing and arm (RH): Boom and bucket (ISO)
Traveling and steering	Two levers with pedals
Engine throttle	Electric, Dial type

SWING SYSTEM

Swing motor	Axial pistons motor
Swing reduction	Planetary gear reduction
Swing bearing lubrication	Grease-bathed
Swing brake	Multi wet disc
Swing speed	8.2 rpm

COOLANT & LUBRICANT CAPACITY

	liter	US gal	UK gal
Refilling			
Fuel tank	621.0	164.0	136.6
Engine coolant	68.0	18.0	15.0
Engine oil	41.6	11.0	9.15
Swing device	5.0	1.3	1.1
Final drive (each)	5.0	1.3	1.1
Hydraulic system (including tank)	480.0	100.4	83.6
Hydraulic tank	262.0	69.2	57.6

UNDERCARRIAGE

The X-leg type center frame is integrally welded with reinforced box-section track frames. The undercarriage includes lubricated rollers, idlers, track adjusters with shock absorbing springs and sprockets, and a track chain with double or triple grouser shoes.

Center frame	X - leg type
Track frame	Pentagonal box type
No. of shoes on each side	53
No. of carrier rollers on each side	2
No. of track rollers on each side	9
No. of rail guards on each side	2

OPERATING WEIGHT (APPROXIMATE)

Operating weight, including 7,060 mm (23' 2") boom, 3,380 mm (11' 1") arm, SAE heaped 2.15m³ (2.81 yd³) bucket, lubricant, coolant, full fuel tank, full hydraulic tank and all standard equipments.

MAJOR COMPONENT WEIGHT	
Upperstructure	10,940 kg (24,120 lb)
Boom (with arm cylinder)	4,110 kg (9,060 lb)

OPERATING WEIGHT			
Shoes	Width mm (in)	Operating weight kg (lb)	Ground pressure kgf/cm ² (psi)
Triple grouser	600 mm (24")	48,100 (106,040)	0.83 (11.80)
	700 mm (28")	48,640 (107,230)	0.72 (10.24)
	750 mm (30")	48,910 (107,830)	0.68 (9.67)
	800 mm (32")	49,180 (108,420)	0.64 (9.10)
	900 mm (36")	49,720 (109,610)	0.57 (8.11)
Double grouser	600 mm (24")	48,100 (106,040)	0.83 (11.80)
	700 mm (28")	48,640 (107,230)	0.72 (10.24)
Triple grouser (Heavy Duty)	600 mm (24")	48,308 (106,500)	0.84 (11.94)
	700 mm (28")	48,870 (107,740)	0.73 (10.38)

BUCKETS R480LC-9A

All buckets are welded with high-strength steel.

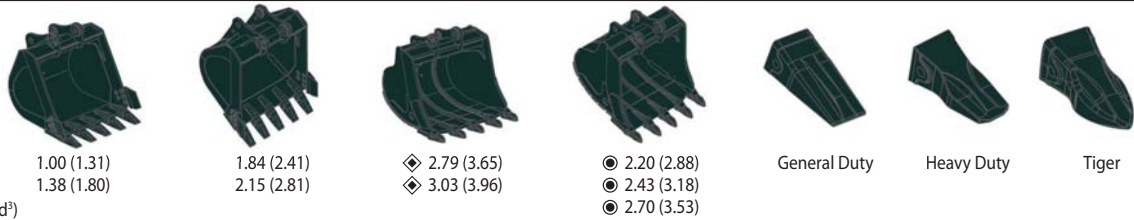

SAE heaped m³ (yd³)

Capacity m ³ (yd ³)		Width mm (in)		Weight kg (lb)	Recommendation m (ft.in)					
SAE heaped	CECE heaped	Without side cutters	With side cutters		7.06 (23' 2") Boom				6.55 (21' 6") Boom	9.0 (29' 6") Boom
					2.4 (7' 10") Arm	2.9 (9' 6") Arm	3.38 (11' 1") Arm	4.0 (13' 1") Arm	2.4 (7' 10") Arm	5.85 (19' 2") Arm
1.00 (1.31)	0.9 (1.17)	915 (36.0)	1,065 (41.9)	1,220 (2,690)	●	●	●	●	●	●
1.38 (1.80)	1.25 (1.63)	1,100 (43.3)	1,250 (49.2)	1,420 (3,130)	●	●	●	●	●	■
1.84 (2.41)	1.65 (2.16)	1,140 (44.9)	1,290 (50.8)	1,520 (3,350)	●	●	●	■	●	-
2.15 (2.81)	1.92 (2.51)	1,415 (55.7)	1,565 (61.6)	1,740 (3,840)	●	●	■	▲	●	-
◆ 2.79 (3.65)	2.47 (3.23)	1,760 (69.3)	1,910 (75.2)	1,960 (4,320)	■	■	▲	-	●	-
◆ 3.03 (3.96)	2.67 (3.49)	1,890 (74.4)	2,040 (80.3)	2,090 (4,610)	▲	▲	-	-	■	-
● 2.20 (2.88)	1.80 (2.35)	1,840 (72.4)	-	2,295 (5,060)	●	●	■	-	●	-
● 2.43 (3.18)	2.10 (2.75)	1,885 (74.2)	-	2,335 (5,150)	▲	-	-	-	■	-
● 2.70 (3.53)	2.5 (3.27)	1,790 (70.4)	-	2,715 (5,990)	▲	-	-	-	■	-

◆ Heavy-duty bucket

● Heavy duty Rock-bucket

● : Applicable for materials with density of 2,000 kg/m³ (3,370 lb/yd³) or less

■ : Applicable for materials with density of 1,600 kg/m³ (2,700 lb/yd³) or less

▲ : Applicable for materials with density of 1,100 kg/m³ (1,850 lb/yd³) or less

ATTACHMENT R480LC-9A

Booms and arms are welded, a low-stress, full-box section design.

6.55 m (21' 6"); 7.06 m (23' 2") & 9.0 m (29' 6") booms and 2.4 m (7' 10"); 2.9 m (9' 6"); 3.38 m (11' 1"); 4.0 m (13' 1") & 5.85 m (19' 2") arms are available.

DIGGING FORCE R480LC-9A

Boom	Length	mm (ft.in)	7,060 (23' 2")				Remarks
	Weight	kg (lb)	3,260 (7,180)				
Arm	Length	mm (ft.in)	2,400 (7' 10")	2,900 (9' 6")	3,380 (11' 1")	4,000 (13' 1")	Power Boost
	Weight	kg (lb)	2,070 (4,560)	2,230 (4,920)	2,100 (4,630)	2,370 (5,220)	
Bucket digging force	SAE	kN	216.7 [236.4]	219.7 [239.6]	220.7 [240.7]	222.6 [242.9]	[]: Power Boost
		kgf	22,100 [24,110]	22,400 [24,440]	22,500 [24,550]	22,700 [24,760]	
		lbf	48,720 [53,150]	49,380 [53,870]	49,600 [54,110]	50,040 [54,590]	
	ISO	kN	251.1 [273.9]	254.0 [277.1]	255.0 [278.2]	256.9 [280.3]	
		kgf	25,600 [27,930]	25,900 [28,250]	26,000 [28,360]	26,200 [28,580]	
		lbf	56,440 [61,570]	57,100 [62,290]	57,320 [62,530]	57,760 [63,010]	
Arm crowd force	SAE	kN	276.6 [301.7]	224.6 [245.0]	191.2 [208.6]	170.6 [186.2]	
		kgf	28,200 [30,760]	22,900 [24,980]	19,500 [21,270]	17,400 [18,980]	
		lbf	62,170 [67,820]	50,490 [55,080]	42,990 [46,900]	38,360 [41,850]	
	ISO	kN	290.3 [316.7]	234.4 [255.7]	199.1 [217.2]	176.5 [192.6]	
		kgf	29,600 [32,290]	23,900 [26,070]	20,300 [22,150]	18,000 [19,640]	
		lbf	65,260 [71,190]	52,690 [57,480]	44,750 [48,820]	39,680 [43,290]	

Note: Boom weight includes arm cylinder, piping and pin.

Arm weight includes bucket cylinder, linkage and pin.

Dimensions & Working Ranges

DIMENSIONS R480LC-9A

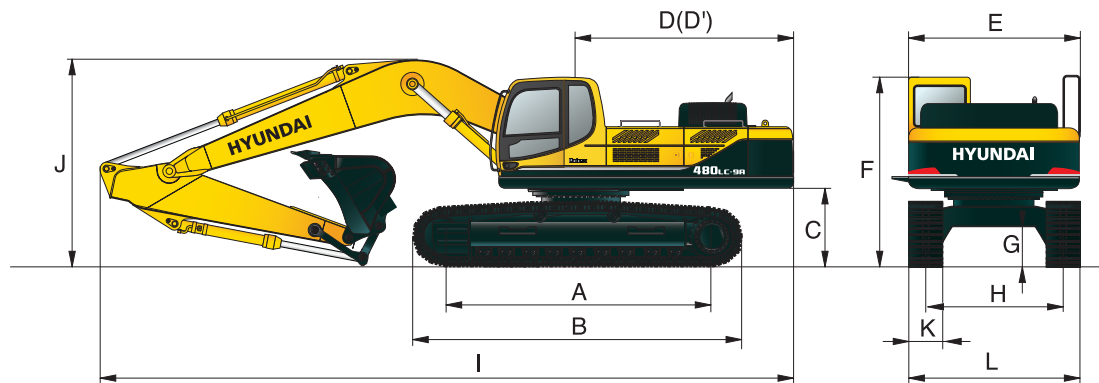

mm (ft - in)

mm (ft - in)

A Tumbler distance	4,470 (14' 8")	Boom length				7,060 (23' 2")	6,550 (21' 6")	9,000 (29' 6")	
B Overall length of crawler	5,462 (17' 11")	Arm length		2,400 (7' 10")	2,900 (9' 6")	3,380 (11' 1")	4,000 (13' 1")	2,400 (7' 10")	5,850 (19' 2")
C Ground clearance of counterweight	1,295 (4' 3")	I Overall length		12,430 (40' 3")	12,360 (40' 0")	12,220 (39' 7")	12,200 (39' 6")	11,930 (38' 7")	13,820 (44' 10")
D Tail swing radius	3,910 (12' 4")	J Overall height of boom		3,840 (12' 7")	3,770 (12' 4")	3,730 (12' 3")	4,040 (13' 3")	4,030 (13' 3")	5,200 (17' 1")
D' Rear-end length	3,855 (12' 1")	K Track shoe width		600 (24")	700 (28")	750 (30")	800 (32")	900 (36")	
E Overall width of upperstructure	2,980 (9' 9")	L Overall width		3,340 (10' 11")	3,440 (11' 3")	3,490 (11' 5")	3,540 (11' 7")	3,640 (11' 11")	
F Overall height of cab	3,190 (10' 6")								
G Min. ground clearance	555 (1' 10")								
H Track gauge	2,740 (9' 0")								

WORKING RANGES R480LC-9A

mm (ft - in)

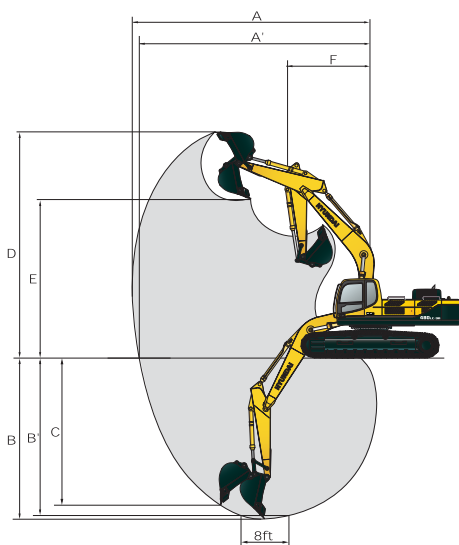

Boom length	7,060 (23' 2")				6,550 (21' 6")	9,000 (29' 6")
Arm length	2,400 (7' 10")	2,900 (9' 6")	3,380 (11' 1")	4,000 (13' 1")	2,400 (7' 10")	5,850 (19' 2")
A Max. digging reach	11,160 (36' 7")	11,550 (37' 11")	12,100 (39' 8")	12,660 (41' 6")	10,610 (34' 10")	16,350 (53' 8")
A' Max. digging reach on ground	10,940 (35' 11")	11,340 (37' 2")	11,900 (39' 1")	12,470 (40' 11")	10,370 (34' 0")	16,200 (53' 2")
B Max. digging depth	6,850 (22' 6")	7,350 (24' 1")	7,810 (25' 7")	8,450 (27' 9")	6,370 (20' 11")	11,560 (37' 11")
B' Max. digging depth (8' level)	6,670 (21' 11")	7,190 (23' 7")	7,670 (25' 2")	8,320 (27' 4")	6,190 (20' 4")	11,460 (37' 7")
C Max. vertical wall digging depth	5,960 (19' 7")	5,930 (19' 5")	6,590 (21' 7")	7,170 (23' 6")	5,400 (17' 9")	10,320 (33' 10")
D Max. digging height	10,560 (34' 8")	10,530 (34' 7")	10,980 (36' 0")	11,210 (36' 9")	10,170 (33' 4")	13,840 (45' 5")
E Max. dumping height	7,120 (23' 4")	7,180 (23' 7")	7,620 (25' 0")	7,820 (25' 8")	6,750 (22' 2")	10,440 (34' 3")
F Min. front swing radius	5,090 (16' 8")	4,910 (16' 1")	4,780 (15' 8")	4,910 (16' 1")	4,620 (15' 2")	5,940 (19' 6")

Lifting Capacities



R480LC-9A

Rating over-front Rating over-side or 360 degrees

Boom : 6.55 m (21' 6") / Arm : 2.40 m (7' 10") / Bucket : 2.15 m³ (2.81 yd³) SAE heaped / Shoe : 600 mm (24") triple grouser

Load point height m (ft)	Load radius								At max. reach			
	3.0 m (10 ft)		4.5 m (15 ft)		6.0 m (20 ft)		7.5 m (25 ft)		Capacity		Reach m (ft)	
6.0 m (25 ft)	kg				*12480	*12480	*11020	9310	*9470	6570	9.15	
	lb				*27510	*27510	*24290	20530	*20880	14480	(30.0)	
4.5 m (20 ft)	kg		*18440	*18440	*13960	13040	11650	9010	*9440	5790	9.65	
	lb		*40650	*40650	*30780	28750	25680	19860	*20810	12760	(31.7)	
3.0 m (15 ft)	kg				*15580	12220	12420	8610	*9470	5410	9.86	
	lb				*34350	26940	27380	18980	*20880	11930	(32.3)	
1.5 m (5 ft)	kg				*16700	11550	13000	8240	*9510	5340	9.80	
	lb				*36820	25460	28660	18170	*20970	11770	(32.2)	
Ground Line	kg		*22790	17330	*16900	11170	13090	8000	*9480	5590	9.47	
	lb		*50240	38210	*37260	24630	28860	17640	*20900	12320	(31.1)	
-1.5 m (-5 ft)	kg	*25320	*25320	*20990	17370	*16060	11060	12360	7920	*9240	6280	8.83
	lb	*55820	*55820	*46270	38290	*35410	24380	27250	17460	*20370	13850	(29.0)
-3.0 m (-10 ft)	kg	*21780	*21780	*17910	17670	*13920	11190			*8390	7800	7.79
	lb	*48020	*48020	*39480	38960	*30690	24670			*18500	17200	(25.6)
-4.5 m (-15 ft)	kg			*12770	*12770							
	lb			*28150	*28150							

Boom : 7.06 m (23' 2") / Arm : 2.40 m (7' 10") / Bucket : 2.15 m³ (2.81 yd³) SAE heaped / Shoe : 600 mm (24") triple grouser

Load point height m (ft)	Load radius								At max. reach				
	3.0 m (10 ft)		4.5 m (15 ft)		6.0 m (20 ft)		7.5 m (25 ft)		9.0 m (30 ft)		Capacity		Reach m (ft)
6.0 m (20 ft)	kg				*12000	*12000	*10370	9210			*8610	5730	9.75
	lb				*26460	*26460	*22860	20300			*18980	12630	(32.0)
4.5 m (15 ft)	kg				*13640	12660	*11150	8820			*8600	5100	10.21
	lb				*30070	27910	*24580	19440			*18960	11240	(33.5)
3.0 m (10 ft)	kg				*15310	11770	*12010	8370	*10080	6180	8630	4780	10.41
	lb				*33750	25950	*26480	18450	*22220	13620	19030	10540	(34.2)
1.5 m (5 ft)	kg				*16370	11110	*12650	7990	*10340	5980	8590	4720	10.36
	lb				*36090	24490	*27890	17610	*22800	13180	18940	10410	(34.0)
Ground Line	kg				*16540	10780	*12830	7740	*10270	5850	*8720	4930	10.05
	lb				*36460	23770	*28290	17060	*22640	12900	*19220	10870	(33.0)
-1.5 m (-5 ft)	kg		*20270	16950	*15820	10710	*12360	7660			*8570	5470	9.46
	lb		*44690	37370	*34880	23610	*27250	16890			*18890	12060	(31.0)
-3.0 m (-10 ft)	kg	*20660	*20660	*17780	17250	*14130	10850	*10900	7770		*8040	6620	8.51
	lb	*45550	*45550	*39200	38030	*31150	23920	*24030	17130		*17730	14590	(27.9)
-4.5 m (-15 ft)	kg			*13800	*13800	*10900	*10900				*6360	*6360	7.04
	lb			*30420	*30420	*24030	*24030				*14020	*14020	(23.1)













- Lifting capacity is based on SAE J1097, ISO 10567.
- Lifting capacity of the Robex Series does not exceed 75% of the tipping load with the machine on firm, level ground or 87% of full hydraulic capacity.
- The load point is a hook located on the back of the bucket.
- (*) indicates the load limited by hydraulic capacity.

Lifting Capacities













R480LC-9A

 Rating over-front  Rating over-side or 360 degrees

Boom : 7.06 m (23' 2") / Arm : 2.90 m (9' 6") / Bucket : 2.15 m³ (2.81 yd³) SAE heaped / Shoe : 600 mm (24") triple grouser

Load point height m (ft)	Load radius										At max. reach		
	3.0 m (10 ft)		4.5 m (15 ft)		6.0 m (20 ft)		7.5 m (25 ft)		9.0 m (30 ft)		Capacity	Reach	
													m (ft)
6.0 m (20 ft)	kg						*9720	9320			*7970	5290	10.17
	lb						*21430	20550			*17570	11660	(33.4)
4.5 m (15 ft)	kg		*17130	*17130	*12810	*12810	*10570	8900	*9230	6420	*8010	4720	10.62
	lb		*37770	*37770	*28240	*28240	*23300	19620	*20350	14150	*17660	10410	(34.8)
3.0 m (10 ft)	kg		*20840	18260	*14600	11920	*11520	8410	*9700	6170	8080	4430	10.80
	lb		*45940	40260	*32190	26280	*25400	18540	*21380	13600	17810	9770	(35.4)
1.5 m (5 ft)	kg		*22630	17010	*15920	11160	*12300	7970	*10090	5930	8030	4360	10.75
	lb		*49890	37500	*35100	24600	*27120	17570	*22240	13070	17700	9610	(35.3)
Ground Line	kg		*22430	16650	*16410	10720	*12670	7670	*10200	5760	*8290	4520	10.46
	lb		*49450	36710	*36180	23630	*27930	16910	*22490	12700	*18280	9960	(34.3)
-1.5 m (-5 ft)	kg	*19830	*19830	*21180	16670	*16030	10560	*12460	7530		*8270	4970	9.89
	lb	*43720	*43720	*46690	36750	*35340	23280	*27470	16600		*18230	10960	(32.4)
-3.0 m (-10 ft)	kg	*24070	*24070	*18990	16910	*14720	10630	*11420	7570		*8000	5900	9.00
	lb	*53070	*53070	*41870	37280	*32450	23440	*25180	16690		*17640	13010	(29.5)
-4.5 m (-15 ft)	kg	*19160	*19160	*15510	*15510	*12130	10930				*7000	*7000	7.64
	lb	*42240	*42240	*34190	*34190	*26740	24100				*15430	*15430	(25.1)

Boom : 7.06 m (23' 2") / Arm : 3.38 m (11' 1") / Bucket : 2.15 m³ (2.81 yd³) SAE heaped / Shoe : 600 mm (24") triple grouser

Load point height m (ft)	Load radius										At max. reach			
	3.0 m (10 ft)		4.5 m (15 ft)		6.0 m (20 ft)		7.5 m (25 ft)		9.0 m (30 ft)		Capacity	Reach		
													m (ft)	
6.0 m (20 ft)	kg							*9220	*9220	*8240	6740	*7490	4800	10.75
	lb							*20330	*20330	*18170	14860	*16510	10580	(35.3)
4.5 m (15 ft)	kg					*12140	*12140	*10130	9050	*8910	6530	*7530	4320	11.17
	lb					*26760	*26760	*22330	19950	*19640	14400	*16600	9520	(36.6)
3.0 m (10 ft)	kg		*19830	18930	*14060	12170	*11170	8540	*9450	6260	7470	4070	11.35	
	lb		*43720	41730	*31000	26830	*24630	18830	*20830	13800	16470	8970	(37.2)	
1.5 m (5 ft)	kg		*22320	17460	*15610	11360	*12080	8080	*9940	5990	7420	4010	11.30	
	lb		*49210	38490	*34410	25040	*26630	17810	*21910	13210	16360	8840	(37.1)	
Ground Line	kg		*22800	16860	*16390	10850	*12610	7730	*10190	5790	7670	4140	11.02	
	lb		*50270	37170	*36130	23920	*27800	17040	*22470	12760	16910	9130	(36.2)	
-1.5 m (-5 ft)	kg	*18070	*18070	*21950	16730	*16290	10610	*12600	7550	*10010	5680	*7770	4500	10.49
	lb	*39840	*39840	*48390	36880	*35910	23390	*27780	16640	*22070	12520	*17130	9920	(34.4)
-3.0 m (-10 ft)	kg	*24350	*24350	*20080	16870	*15280	10820	*11850	7530		*7590	5240	9.66	
	lb	*53680	*53680	*44270	37190	*33690	23850	*26120	16600		*16730	11550	(31.7)	
-4.5 m (-15 ft)	kg	*22100	*22100	*16990	*16990	*13120	10820	*9890	7710		*6910	6720	8.43	
	lb	*48720	*48720	*37460	*37460	*28920	23850	*21800	17000		*15230	14820	(27.7)	
-6.0 m (-20 ft)	kg			*11930	*11930	*8900	*8900							
	lb			*26300	*26300	*19620	*19620							

- Lifting capacity is based on SAE J1097, ISO 10567.
- Lifting capacity of the Robex Series does not exceed 75% of the tipping load with the machine on firm, level ground or 87% of full hydraulic capacity.
- The load point is a hook located on the back of the bucket.
- (*) indicates the load limited by hydraulic capacity.

Lifting Capacities



R480LC-9A

Rating over-front Rating over-side or 360 degrees

Boom : 7.06 m (23' 2") / Arm : 4.00 m (13' 1") / Bucket : 2.15 m³ (2.81 yd³) SAE heaped / Shoe : 600 mm (24") triple grouser

Load point height m (ft)	Load radius												At max. reach			
	3.0 m (10 ft)		4.5 m (15 ft)		6.0 m (20 ft)		7.5 m (25 ft)		9.0 m (30 ft)		10.5 m (35 ft)		Capacity		Reach	
															m (ft)	
6.0 m (20 ft)	kg									*7750	6810			*6780	4260	11.35
	lb									*17090	15010			*14950	9390	(37.2)
4.5 m (15 ft)	kg						*9300	9140		*8250	6560	*5010	4790	*6840	3840	11.75
	lb						*20500	20150		*18190	14460	*11050	10560	*15080	8470	(38.5)
3.0 m (10 ft)	kg			*17970	*17970	*13000	12370	*10430	8590	*8880	6250	*6710	4630	6790	3610	11.91
	lb			*39620	*39620	*28660	27270	*22990	18940	*19580	13780	*14790	10210	14970	7960	(39.1)
1.5 m (5 ft)	kg			*21130	17770	*14790	11450	*11470	8070	*9480	5940	*7610	4460	6730	3550	11.87
	lb			*46580	39180	*32610	25240	*25290	17790	*20900	13100	*16780	9830	14840	7830	(38.9)
Ground Line	kg	*13120	*13120	*22460	16830	*15900	10800	*12200	7650	*9880	5680	*7180	4330	6920	3640	11.60
	lb	*28920	*28920	*49520	37100	*35050	23810	*26900	16870	*21780	12520	*15830	9550	15260	8020	(38.1)
-1.5 m (-5 ft)	kg	*17270	*17270	*22270	16480	*16180	10450	*12440	7390	*9940	5520			*7210	3930	11.11
	lb	*38070	*38070	*49100	36330	*35670	23040	*27430	16290	*21910	12170			*15900	8660	(36.5)
-3.0 m (-10 ft)	kg	*22170	*22170	*20930	16490	*15580	10350	*12030	7300	*9420	5480			*7150	4500	10.34
	lb	*48880	*48880	*46140	36350	*34350	22820	*26520	16090	*20770	12080			*15760	9920	(33.9)
-4.5 m (-15 ft)	kg	*25260	*25260	*18420	16750	*13970	10470	*10700	7390					*6800	5600	9.21
	lb	*55690	*55690	*40610	36930	*30800	23080	*23590	16290					*14990	12350	(30.2)
-6.0 m (-20 ft)	kg	*18790	*18790	*14270	*14270	*10820	*10820							*5580	*5580	7.55
	lb	*41420	*41420	*31460	*31460	*23850	*23850							*12300	*12300	(24.8)

Boom : 9.0 m (29' 6") / Arm : 5.85 m (19' 2") / Bucket : 1.38 m³ (1.80 yd³) SAE heaped / Shoe : 600 mm (24") triple grouser

Load point height m (ft)	Load radius												At max. reach			
	3.0 m (10 ft)		5.0 m (15 ft)		7.0 m (25 ft)		9.0 m (30 ft)		11.0 m (35 ft)		13.0 m (45 ft)		Capacity		Reach	
															m (ft)	
10.0 m (35 ft)	kg													*4310	3590	13.54
	lb													*9500	7910	(44.4)
8.0 m (25 ft)	kg											*2660	*2660	*4240	2910	14.55
	lb											*5860	*5860	*9350	6420	(44.7)
6.0 m (20 ft)	kg									*5190	*5190	*4250	3640	*4230	2490	15.20
	lb									*11440	*11440	*9370	8020	*9330	5490	(49.9)
4.0 m (15 ft)	kg							*6800	*6800	*5710	4950	*4990	3450	*4270	2240	15.55
	lb							*14990	*14990	*12590	10910	*11000	7610	*9410	4940	(51.0)
2.0 m (5 ft)	kg			*16010	16000	*10420	9730	*7780	6520	*6260	4560	*5280	3230	*4320	2110	15.61
	lb			*35300	35270	*22970	21450	*17150	14370	*13800	10050	*11640	7120	*9520	4650	(51.2)
Ground Line	kg			*16790	14290	*11730	8750	*8570	5940	*6720	4210	*5510	3020	*4390	2110	15.38
	lb			*37020	31500	*25860	19290	*18890	13100	*14820	9280	*12150	6660	*9680	4650	(50.5)
-2.0 m (-5 ft)	kg	*10920	*10920	*17330	13650	*12300	8170	*9000	5540	*6970	3950	*5550	2880	*4450	2250	14.87
	lb	*24070	*24070	*38210	30090	*27120	18010	*19840	12210	*15370	8710	*12240	6350	*9810	4960	(48.8)
-4.0 m (-15 ft)	kg	*14070	*14070	*17370	13550	*12100	7950	*8940	5340	*6850	3820	*4730	2830	*4450	2560	14.02
	lb	*31020	*31020	*38290	29870	*26680	17530	*19710	11770	*15100	8420	*10430	6240	*9810	5640	(46.0)
-6.0 m (-20 ft)	kg	*17730	*17730	*15490	13780	*11110	7980	*8260	5340	*6160	3850			*4320	3160	12.76
	lb	*39090	*39090	*34150	30380	*24490	17590	*18210	11770	*13580	8490			*9520	6970	(41.9)
-8.0 m (-25 ft)	kg	*17880	*17880	*12400	*12400	*9090	8270	*6620	5560					*3820	*3820	10.94
	lb	*39420	*39420	*27340	*27340	*20040	18230	*14590	12260					*8420	*8420	(35.9)
-10.0 m (-35 ft)	kg					*5220	*5220									
	lb					*11510	*11510									

- Lifting capacity is based on SAE J1097, ISO 10567.
- Lifting capacity of the Robex Series does not exceed 75% of the tipping load with the machine on firm, level ground or 87% of full hydraulic capacity.
- The load point is a hook located on the back of the bucket.
- (*) indicates the load limited by hydraulic capacity.

STANDARD EQUIPMENT R480LC-9A

ISO Standard cabin

All-weather steel cab with 360° visibility
 Safety glass windows
 Rise-up type windshield wiper
 Sliding fold-in front window
 Sliding side window (LH)
 One key fits all lockable doors
 Hot & cool box
 Storage compartment & Ashtray
 Transparent cabin roof-cover
 Radio / MP3 Player with remote control and USB-input
 Handsfree mobile phone system with USB-charging device,
 12 volt power outlet (24V DC to 12V DC converter)
 Sun visor

Computer aided power optimization (CAPO) system

3-power modes, 2-work modes, User mode
 Auto & one-touch deceleration system
 Auto warm-up system
 Auto Overheat prevention system

Automatic temperature control

Air conditioner & heater
 Defroster

Self-diagnostics system

Starting Aid (air grid heater) for cold weather

Centralized monitoring

LCD display
 Engine speed or Trip meter/Accel.
 Clock
 Gauges
 - Fuel level gauge
 - Engine coolant temperature gauge
 - Hyd. oil temperature gauge
 Warning lamps
 - Engine warning
 - Overload
 - Communication error
 - Low battery
 - Air filter clogging
 Indicators
 - Max power
 - Low speed/High speed
 - Fuel warmer
 - Auto deceleration

Three outside rearview mirrors

Mechanical suspension seat with heater

Adjustable joysticks

Console box height adjust system

Four frontal working lights, one rear light

Electric horn

Batteries (2 x 12V x 200 AH)

Battery master switch

Removable clean-out screen for coolers

Automatic swing brake

Automatic fuel line deaeration

Fuel pre-filter with fuel warmer

Boom holding system

Arm holding system

Track shoes (600 mm; 24")

Track rail guard

Accumulator for lowering work equipment

Electric transducer

Lower frame under cover

Viscous fan clutch

Travel alarm

Rear work Lamp

Smart key

Predeaner (Dry)

OPTIONAL EQUIPMENT R480LC-9A

Fuel filler pump (50 ℓ/min)

Beacon lamp

Safety lock valve for boom cylinder with overload warning device

Safety lock valve for arm cylinder

Single-acting piping kit (breaker, etc.)

Double-acting piping kit (clamshell, etc.)

Quick coupler

Booms

Heavy duty boom (7.06 m; 23' 2")

Short boom (6.55 m; 21' 6")

Long boom (9.0 m; 29' 6")

Arms

Heavy duty arm (3.38 m; 11' 1")

Super short arm (2.4 m; 7' 10")

Short arm (2.9 m; 9' 6")

Long arm (5.85 m; 19' 2")

Counterweight

9,200 kg; (20,280 lb)

9,700 kg; (21,380 lb)

10,200 kg; (22,490 lb)

10,700 kg; (23,590 lb)

Climate control

Air conditioner only

Heater only

Cabin FOPS/FOG (ISO/DIS 10262)-Level II

FOPS (Falling Object Protective Structure)

FOG (Falling Object Guard)

Cabin ROPS (ISO 12117-2)

ROPS (Roll Over Protective Structure)

Cabin guard front

Wire net

Fine net

Cabin roof-steel cover

Cabin lights

Cabin rain guard - front window

Track shoes

Triple grousers shoe (700 mm; 28") (Heavy Duty Type)

Triple grousers shoe (600 mm; 24") (Heavy Duty Type)

Triple grousers shoe (700 mm; 28")

Triple grousers shoe (750 mm; 30")

Triple grousers shoe (800 mm; 32")

Triple grousers shoe (900 mm; 36")

Double grousers shoe (600 mm; 24")

Double grousers shoe (700 mm; 28")

Full track rail guard

Additional lower frame - reinforced under cover

Tool kit

Operator suit

Seat

Adjustable air suspension seat with heater

Rearview camera

Pattern change valve (2 patterns)

Hi-mate (Remote Management System)

Air compressor

* Standard and optional equipment may vary. Contact your Hyundai dealer for more information. The machine may vary according to international standards.

* The photos may include attachments and optional equipment that are not available in your area.

* Materials and specifications are subject to change without advance notice.

* All imperial measurements rounded off to the nearest pound or inch.

PLEASE CONTACT

 **HYUNDAI**
 HEAVY INDUSTRIES EUROPE
CONSTRUCTION EQUIPMENT