

LOADER

23.14

new!



officine
PICCINI®

LOADER

23.14

Informazioni tecniche

Technical information



Motore / Engine

Marca - tipo / Brand - Type	Perkins 1004 - 40T
Raffreddamento / Cooling system	Acqua / Water
Cilindro - cilindri / Cylindres	3990 cm ³ / 4
Potenza netta / Power	73.5 kW @ 2300 rpm

Prestazioni / Performance

Capacità nominale / Rated bucket capacity (ISO 7546)	1.5 m ³
Larghezza / Width	2400 mm
Forza di strappo al dente / Breakout force	8350 kg
Carico statico al limite del ribaltamento / Static tipping load	
Macchina dritta / straight machine	6700 kg
Macchina articolato a 33° / Full turn	6200 kg
Profondità di scavo sotto piano terra / excavation height under the ground level	80 mm
Angolo di richiamo a terra / Articulation angle	45°

Trasmissione / Transmission

Idrostatica con pompa e motore a cilindrata variabile / Hydrostatic with pump and motor at variable displacement	<input checked="" type="checkbox"/>
Trazione integrale 4x4 / 4 wheel drive	<input checked="" type="checkbox"/>

Velocità / Speed

Lavoro lento / Operating mode slow	0.5 km/h
Lavoro veloce / Operating mode fast	0.12 km/h
Trasferimento lento / Travelling mode slow	0.15 km/h
Trasferimento veloce / Travelling mode fast	0.35 km/h

Pneumatici / Tyres

Tipo / Type	17.5 25
-------------	---------

Freni / Brakes

Idrraulici a dischi in bagno d'olio / Hydraulically actuated disc brakes	<input checked="" type="checkbox"/>
--	-------------------------------------

Sterzo / Steering

Articolata Servoassistito con due cilindri / Articulated power assisted	<input checked="" type="checkbox"/>
---	-------------------------------------

Impianto Idrraulico di servizio / Service hydraulic system

Pompa ad ingranaggi / Gear pump	n. 3
Portata massima / Max. flow rate	200 lt./1'
Pressione max di esercizio / Max. working pressure	210 bar

Scambiatore di calore / Oil cooler



Serbatoi / Tanks

Combustibile / Fuel	90 lt.
Olio idraulico / Hydraulic oil	140 lt.

Impianto elettrico / Electric system

Tensione / Operating voltage	12V
Batteria / Battery	160 Ah
Alternatore / Alternator	12V-55 A

Peso operativo / operating weight

8200 kg

Dimensioni / Dimensions

Altezza / Overall Height	3030 mm
Passo / Wheelbase	2390 mm
Larghezza / Width	2400 mm
Lunghezza / Overall Length	6340 mm

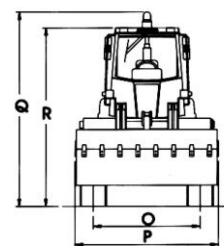
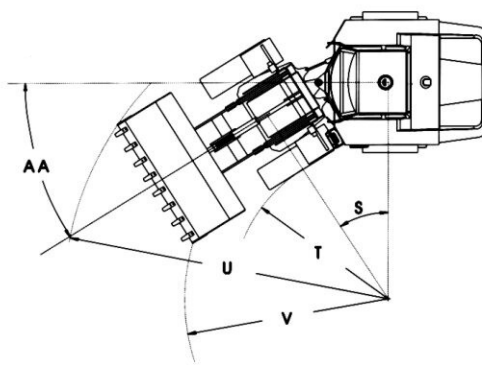
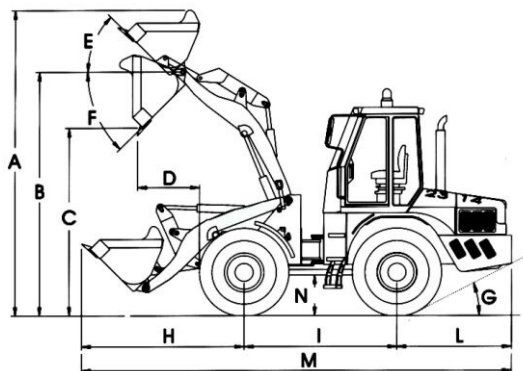

A	4535 mm	G	30°	O	1790 mm	U	5450 mm
B	3570 mm	H	2230 mm	P	2400 mm	V	3430 mm
C	2800 mm	I	2390 mm	Q	3330 mm	AA	33°
D	960 mm	L	1720 mm	R	3030 mm		
E	45°	M	6340 mm	S	33°		
F	42°	N	600 mm	T	2440 mm		



S.S. Trasimeno Ovest 161/c
06132 Perugia -Italy
Tel. +39 075 51801 - Fax +39 075 5179166
Web Site: www.officinepiccini.it
E-Mail: info@officinepiccini.it

Vendite Italia 075 5180239
Assistenza 075 5180221
Export Sales +39 075 5180240
Service +39 075 5180221