

SCOUT 5500

new!



officine
PICCINI®

SCOUT

5500

Caratteristiche tecniche
 Technical features
 Données techniques
 Característica técnicas



MOTORE - ENGINE - MOTEUR - MOTOR

DEUTZ BF4M
 PERKINS 1106C-60TA

POTENZA - POWER - PUISSANCE - POTENCIA

148/112 (HP/KW)
 148/112 (HP/KW)

TRASMISSIONE - TRANSMISSION - TRANSMISSION - TRANSMISSION

Idrostatica - Hydrostatic - Hydrostatique - Hidroestática

4 Ruote Motrici - 4 wheel-drive - 4 roues motrices - 4 ruedas motrices

(Marce idrostatiche + marce meccaniche) - (Hydrostatic speed + mechanical speed) - (Vitesses hydrauliques + mécaniques)
 - (Velocidades hidroestática + mecánicas)

2 + 2

Velocità massima - Max. speed - Vitesse maxi. - Velocidad máxima

30Km/h

STERZO - STEERING - DIRECTION - DIRECCIÓN

Ruote sterzanti - Steering wheels - Roues directrices - Ruedas de dirección

4

3 modalità di sterzata - 3 steering modes - 3 modes de direction - 3 tipos de dirección

FRENI DI SERVIZIO - BRAKES - FREINS - FRENOS

Dischi multipli in bagno d'olio su 4 ruote - Oil immersed multiple disks on 4 wheels - Disques multiples en bain d'huile sur 4 roues - Discos múltiples en baño de aceite en las 4 ruedas

FRENO DI STAZIONAMENTO IDRAULICO - HYDRAULIC PARKING BRAKE - FREIN HYDRAULIQUE DE STATIONNEMENT - FRENO DE ESTACIONAMIENTO HIDRÁULICO

PNEUMATICI - TYRES - PNEUS - NEUMÁTICOS

18/22,5

RAGGIO DI STERZATA INTERNO / ESTERNO - STEERING RADIUS INTERNAL / EXTERNAL - RAYONDEVIRAGE INTÉRIEUR - RADIO VUELTA INTERIOR / EXTERIOR

2,34/4,79 mt.

SERBATOI - TANKS - RÉSERVOIRS - TANQUES

Gasolio - Diesel - Gasoil - Gasóleo

120 lt.

Olio idraulico - Hydraulic oil - Huile hydraulique - Aceite hidráulico

140 lt.

PALA DI CARICO - LOADING SHOVEL - GODET DE CHARGEMENT - CUCHARA DE CARGA Capacità - Capacity - Capacité - Capacidad

650 lt.

Articolazione - Articulation - Articulation - Articulación

CANALA DI SCARICO - DISCHARGE CHUTE - GOULOTTE DE DÉCHARGEMENT - CANALETA DE DESCARGA

Comandata idraulicamente - Hydraulically driven - Commandée hydrauliquement - Controlada hidráulicamente

TAMBURO DI MESCOLAZIONE - MIXING DRUM - CUVE DE MALAXAGE - CUBA DE MEZCLA

Volume totale - Total volume - Volume total - Volumen total

8300 lt.

Resa calcestruzzo - Concrete output - Débit béton - Capacidad hormigón

5800 lt.

Inclinazione tamburo - Drum inclination - Inclination cuve - Inclinación cuba

14°

IMPIANTO ACQUA - WATER SYSTEM - INSTALLATION EAU - INSTALACIÓN AGUA

Capacità serbatoio - Water tank - Réservoir d'eau - Tanque de agua

950 lt.

Conta litri - Litter meter - Compte litres - Medidor de litros

Lancia di lavaggio - Washing nozzle - Lance de lavage - Lanza de lavado

CABINA ROPS/FOPS - ROPS/FOPS CAB - CABINE ROP / FOPS - CABINA ROPS / FOPS

PESO OPERATIVO - OPERATING WEIGHT - POIDS OPÉRATIONNEL - PESO OPERACIONAL

6.500 kg

SCOUT

5500

Caratteristiche tecniche
 Technical features
 Données techniques
 Característica técnicas



Stabilità della macchina in ogni condizione di scarico
 Machine stability in every condition of discharge
 Stabilité de la machine dans toutes les conditions de déchargement
 Estabilidad de la máquina en cada condición de descarga

Canaletta di scarico comandata idraulicamente
 Discharge chute hydraulically driven
 Goulotte de déchargement commandée hydrauliquement
 Mando hidráulico para canaletta de descarga



Scarico laterale a 90°
 90° side discharge
 Déversement sur côté à 90°
 Descarga lateral a 90°

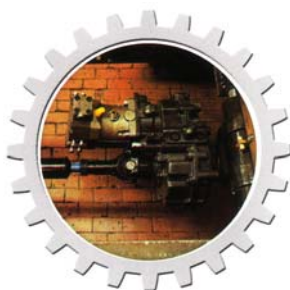

Trasmissione idrostatica con pompa e motore a portata variabile
 Hydrostatic transmission with variable displacement pump and motor
 Transmission hydrostatique avec moteur et pompe à débit variable
 Transmisión hidrostática con motor y bomba a caudal variable

Grande facilità di accesso al vano motore
 Easy access to the engine compartment
 Grande facilité d'accès au moteur
 Gran facilidad de acceso al motor

Grande trazione fuoristrada
 High - power off road drive
 Grande puissance en tout-terrain
 Gran potencia en todo terreno

Sedile super-comfort
 Super - comfort seat
 Siège super - confort
 Asiento súper - confort

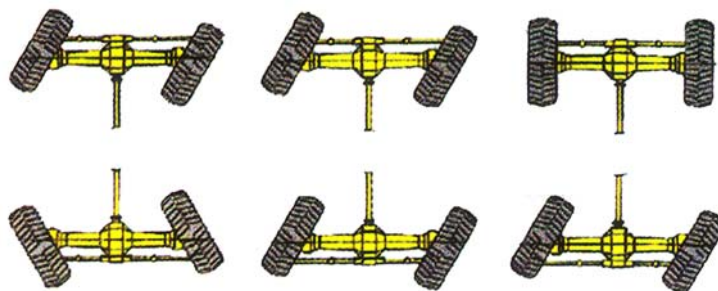

Modalità di sterzata - Steering mode - Modes de direction - Tipos de dirección
 1) 4 Ruote sterzanti - Wheel drive - Roues motrices - Tracción a las 4 rudes
 2) Modalità granchio - Crab type - Modalité à crabe - Modo a cangrejo
 3) 2 ruote sterzanti - Wheel drive - Roues motrices - Tracción a las 2 ruedas

SCOUT 5500

Caratteristiche tecniche
Technical features
Données techniques
Característica técnicas



ACCESSORI – ACCESSORIES – ACCESSOIRES - ACCESORIOS

Lampeggiante magnetico Yellow Blinking light Clignotant à lumière magnétique Bombilla de aviso	✓
Impianto luci per circolazione su strada Road use Lighting System Installation d'éclairage pour circulation sur route Instalación de luces para circulación vial	✓
Omologazione stradale Road homologation for road use Homologation pour circulation sur roue Omologación para circulación vial	✓
Pesa elettronica su pala auto-caricante Electronic weighing scale on loading bucket Bascule électronique sur pelle auto chargeuse Balanza electrónica en la pala auto cargante	✓
Pesa elettronica su tamburo Electronic weighing scale on the mixing drum Bascule électronique sur tambour Balanza electrónica en el tambor	✓
Pompa di lavaggio ad alta pressione High pressure washing pump Pompe de lavage à haute pression Bomba de lavado alta presión	✓
Coclea rompi - sacchi idraulica Hydraulic bags breaker screw conveyer Vis bris sac hydraulique Sin fin rompesacos hidráulico	✓
Stampante per impasti dosi e consumi Printer for dosages programs and daily consumptions Imprimante pour dosages, formules et consommations Impresora para dosificaciones, formulas consumos	✓



Bilancia elettronica
Electronic weigh-batching system
Système de pesage électrique
Balanza electrónica



Pompa acqua auto pescante con contatori
Self-priming water pump with water-meter
Pompe à eau autoamorçante avec compte litres
Bomba de agua con cuenta-litros

DIMENSIONI – DIMENSIONS – DIMENSIONS - DIMENSIONES

A	2500
B	2400
C	1940
D	3500
D1	3060
E	4033
F	1604
G	2600
H	1800
L	6004
M	7260
N	420
O	1470

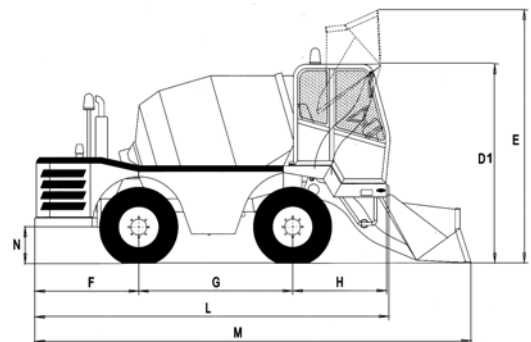
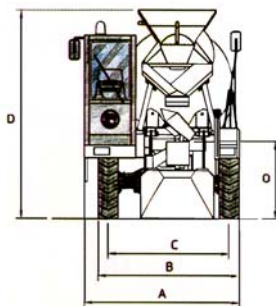

S.S. Trasimeno Ovest 161/c
06132 Perugia -Italy
Tel. +39 075 51801 - Fax +39 075 5179166
Web Site: www.officinepiccini.it
E-Mail: info@officinepiccini.it

Vendite Italia	075 5180239
Assistenza	075 5180221
Export Sales	+39 075 5180240
Service	+39 075 5180221