

TECHNICAL SPECIFICATIONS

Overall Specification	Model	SYG5418THB 52
Length		13850 mm
Width		2500 mm
Height		4000 mm
Total weight		40850 kg

Note: The overall specifications are based on Chassis BENZ Actros 4141.

Dimensions will vary with different truck makes, models and specifications.

Weights are approximate and include pump, boom, truck, full hydraulic oil, driver and some fuel.

Varies with options selected.

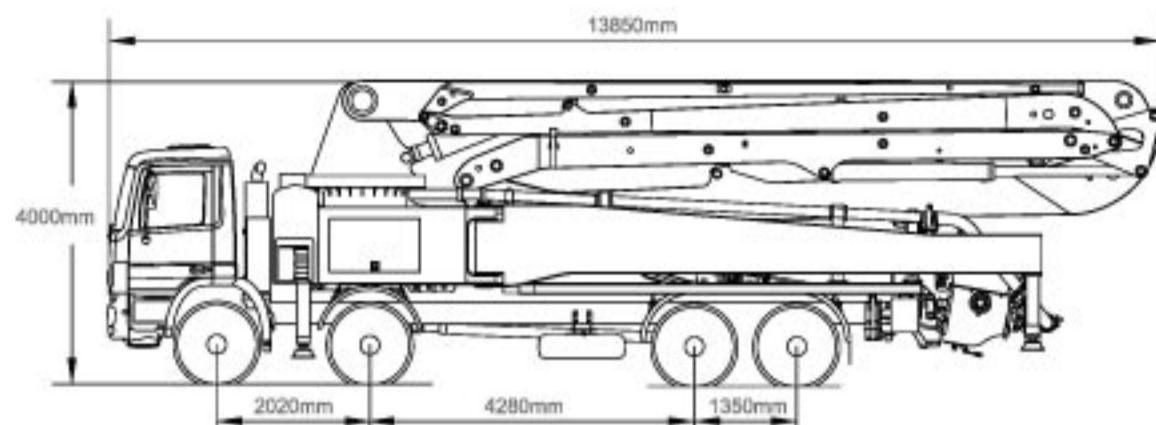

Boom & Outrigger Specification		
Vertical reach		52.0 m
Horizontal reach		48.0 m
Reach depth		33.6 m
Minimum unfolding reach		12.7 m
Arm1	Length	10390 mm
	Angle	90°
Arm2	Length	9230 mm
	Angle	180°
Arm3	Length	8750 mm
	Angle	180°
Arm4	Length	9900 mm
	Angle	240°
Arm5	Length	9905 mm
	Angle	220°
Slewing circle		±360°
Outrigger spread L-R (front)		9470 mm
Outrigger spread L-R (rear)		12680 mm
Outrigger spread width (LH)		10520 mm
Outrigger spread width (RH)		10520 mm

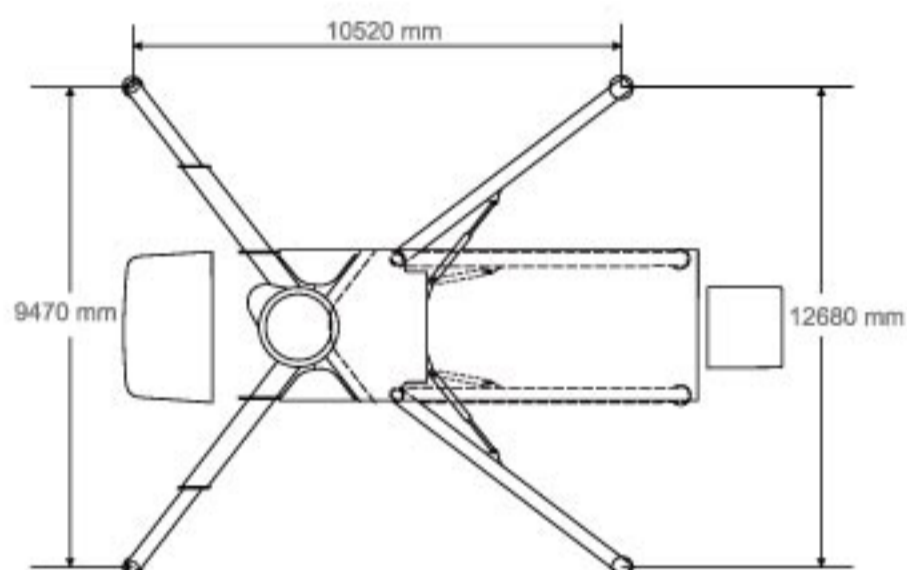

Pumping System Specification		
Output	Low pressure	170 m³/h
	High pressure	120 m³/h
Pressure	Low pressure	8.3 MPa
	High pressure	12 MPa
Max. strokes	Low pressure	24.5 times/min
	High pressure	17 times/min
Delivery cylinder diameter		260 mm
Delivery cylinder stroke		2200 mm
Hydraulic system		Open loop
Hydraulic system oil pressure		max 320 bar
Oil tank capacity		700 L
Water tank capacity		600 L
Pipeline size		125 mm
End hose length		3 m
End hose diameter		125 mm

