

**PR330T/PR330W COLD PLANER****PR330T/PR330W COLD PLANER****Features:**

- Interchangeable work modules permit owners to specify desired cutting configurations.
- 4x4 all-track or -wheel drive, all-track or -wheel steer, anti-spin control.
- Automatic depth (sonic) controls are monitored and adjusted from the operator's position.
- Front-loading, 2-stage conveyor system.
- Rubber shock mounts isolate the following areas: hydraulic tank, fuel tank, operator platform, radiator/cooler.
- Efficient, dependable hydraulic controls and hydrostatic drives.
- Exclusive double-parallelogram rear suspension.
- 80 gallon (310 L) hydraulic storage, fill-by-hand pump through return filter.

## PR330T/PR330W Cold Planer Specifications

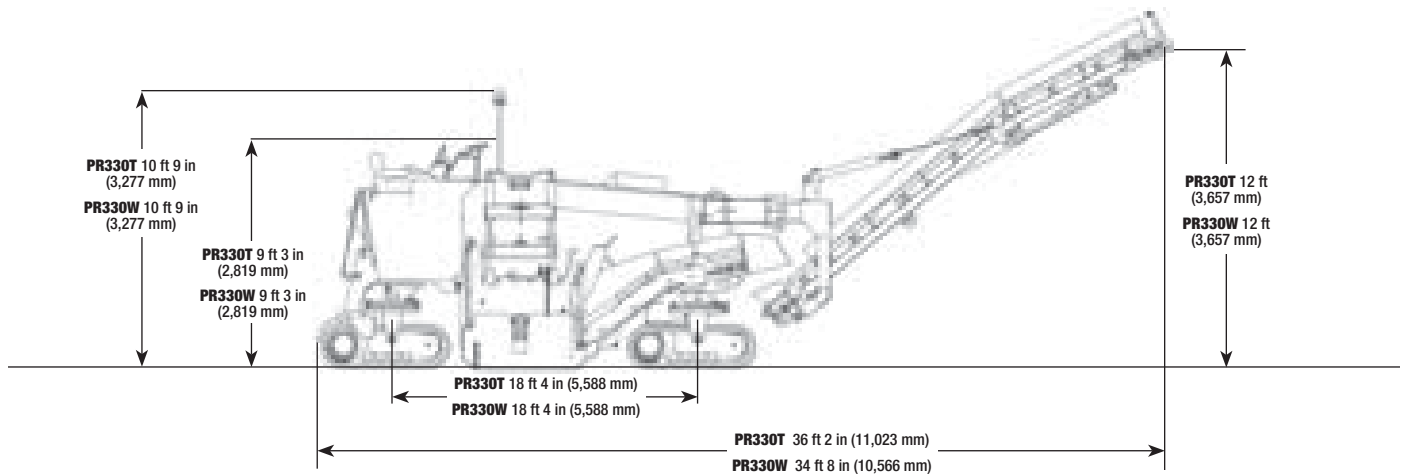

### Features

The Terex® PR330T/PR330W is designed to perform a wide variety of pavement removal jobs. The cutter support structure can accommodate many different types of working attachments. The user can specify cutter drum tool spacing, diameter, width, etc., to shape the machine for optimum profitability on each specific task. The main tractor is highly maneuverable. Its short track base, front and rear steering and state-of-the-art cutter control system make it fast and agile.

### Dimensions

	PR330T	PR330W
Length	36 ft 2 in (11,023 mm)	34 ft 8 in (10,566 mm)
Width	8 ft 6 in (2,591 mm)	8 ft 4 in (2,540 mm)
Height	9 ft 3 in (2,819 mm)	9 ft 3 in (2,819 mm)
Weight with 4 ft (1,219 mm) cutter attachment	41,500 lb (18,870 kg)	40,500 lb (18,370 kg)
Inside turning radius with 4 ft (1,219 mm) cutter attachment		9 ft 8 in (2,946 mm)

### Engine

Make	Cummins® EPA Tier 3
Type	Turbocharged diesel
Model	QSL
Horsepower @ 2,100	330 hp (246 kW)
Electrical	12 volt

### Cutter Assembly

Cutting width	48 in (1,220 mm)
Cutting depth	0–12 in (0–300 mm)

### Cutter Drive System

Power transmission	Hydrostatic, closed-loop
Drive type	Planetary
Crossfall angle	±8 degrees

### Drive System

Drive	4 tracks
Type	Hydrostatic/forward and reverse

#### PR330T Speed ranges:

Working	0–105 ft/min (0–32 m/min)
Traveling	3.2 mph (5.1 km/hr)

#### PR330W Speed ranges:

Working	0–150 ft/min (0–45 m/min)
Traveling	7 mph (11 km/hr)

#### PR330T Track size:

Length	63 in (1,600 mm)
Width	16 in (406 mm)

#### PR330W Wheel size:

Height	36 ft x 20 ft (10,973 mm x 6,0096 mm)
Solid rubber tire	

#### Steering type:

	Hydraulic power
Mode 1	Front steering only
Mode 2	Rear steering only
Mode 3	Front and rear, same (crab)
Mode 4	Coordinated front and rear (cramp)

### Brake System

Parking emergency	Hydraulic disc
Service	Hydrostatic/dynamic

### Conveyor System

Style	Two-stage, front-loading
1st stage length	7 ft 7 in (2,310 mm)
2nd stage length	19 ft (5,791 mm)
Belts width	24 in (610 mm)
Drive system	2-speed, hydraulic variable
2nd stage swing	Hydraulic, 55 degrees left and 35 degrees right
Discharge height	12 ft (3,660 mm)

### Service Refill Capacities

Diesel fuel	118 gal (446 L)
Hydraulic oil	80 gal (310 L)
	<b>PR330T</b> <b>PR330W</b>
Water	375 gal (1,400 L)    400 gal (1,514 L)

### Additional Standard Features

Deluxe operator seat	Vandalism covers
Strobe light beacon	Rubber cutter-drum skirting
Reverse alarm	Matching-key padlocks
Tie-down loops	

### Optional Equipment

Interchangeable work modules
Auto slope/depth-control sonic sensor
Work lights
Laser sensor

Effective Date: July 2009. Product specifications and prices are subject to change without notice or obligation. The photographs and/or drawings in this document are for illustrative purposes only. Refer to the appropriate Operator's Manual for instructions on the proper use of this equipment. Failure to follow the appropriate Operator's Manual when using our equipment or to otherwise act irresponsibly may result in serious injury or death. The only warranty applicable to our equipment is the standard written warranty applicable to the particular product and sale and Terex makes no other warranty, express or implied. Products and services listed may be trademarks, service marks or trade names of Terex Corporation and/or its subsidiaries in the USA and other countries. All rights are reserved. Terex is a registered trademark of Terex Corporation in the USA and many other countries. Copyright 2009 Terex Corporation.

Terex Roadbuilding  
P.O. Box 1985, Oklahoma City, OK 73101  
(405) 787.6020 1-888-TEREXRB  
www.terexrb.com

