

Dynapac CC1200C Plus

Combi rollers



Technical data



Masses

Max. operating mass	2,570 kg
Operating mass (incl. ROPS)	2,430 kg
Module mass (front/rear)	1,260/1,170 kg



Traction

Speed range (Dual/TC/AS)	0-9,5 km/h
Theor. gradeability	63 %



Compaction

Wheel load	290 (kg/wheel)
Tyre type (smooth)	640x240-15
Centrifugal force	33 kN
Nominal amplitude	0.5 mm
Static linear load	10.5 kg/cm
Vibration frequency	63 Hz
Water tank	160 l
Emulsion tank	30 l



Engine

Manufacturer/Model	Kubota D1703-M
Type	Water cooled
Rated power, SAE J1995	26 kW (35 hp) @ 2,800 rpm
Fuel tank capacity	50 l



Hydraulic system

Driving	Axial piston pump with variable displacement. Radial piston motors (3) with constant displacement.
Vibration	Gear pump/motors with constant displacement.
Steering	Gear pump with constant displacement.
Service brake	Hydrostatic in forward and reverse lever.
Parking/ Emergency brake	Failsafe multidisc on drum and wheel motors.

Find us locally at www.atlascopco.com

We reserve the right to change specifications without notice. Photos and illustrations do not always show standard versions of machines. The above information is a general description only, all informations are supplied without liability.

rce_cc1200c_plus_en-20140905.112525.pdf 2014-09-05 11:25

Dynapac CC1200C Plus

Combi rollers

Atlas Copco

Technical data

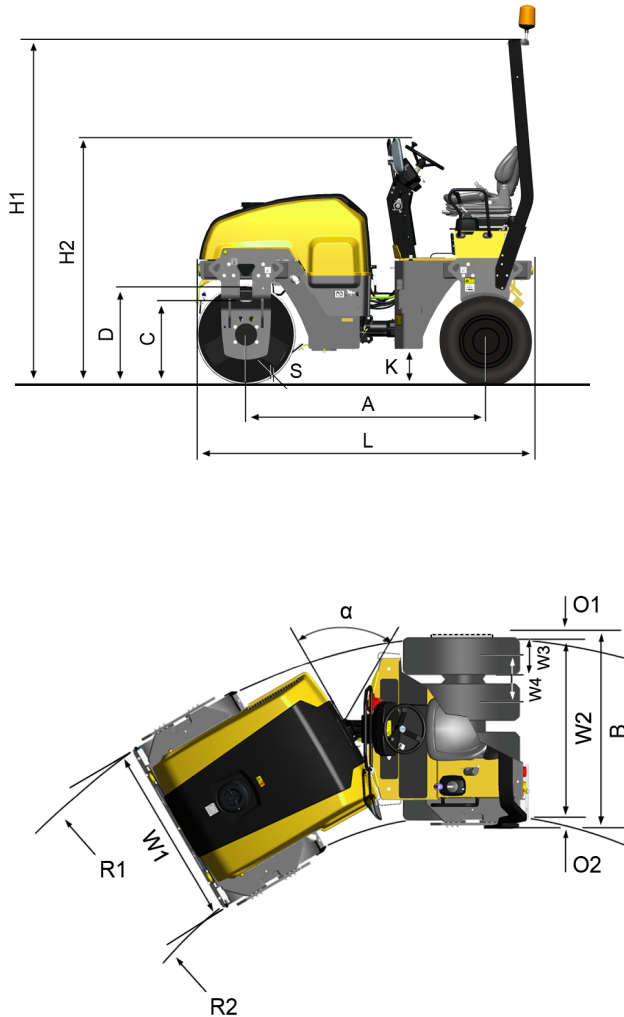

Equipment package		
CC Plus Package	Included	Optional
Backup alarm	■	
Brake release	■	
CE sign	■	
Driving lights, right or left handed		■
Dual arm rest	■	
Dual forward/reverse control		■
Dual frequency		■
Flow divider		■
Foldable ROPS incl. seatbelt	■	
Rotating beacon	■	
Rotating beacon, ignition controlled		■
Slideable comfort seat	■	
Slideable lux seat		■
Spring loaded scrapers		■
Sprinkler timer	■	
Vibr. shut off, front drum	■	
Working lights	■	

Standard equipment
Backup alarm, Working lights

Optional equipment
3" seatbelt, Biodegradable hydraulic fluid, Cert. Fire protection (SBF 127), Decal risk location (GOST), Fire extinguisher, Foot rest Hearing protectors, Licence plate light, Rear view mirror (traffic view), Service kit 50/500/1000H, Side direction lights (driving lights required), Slow moving vehicle sign, Special color (one or two), Tool set, Towing eyelet, Water tank cover (lockable)

Find us locally at www.atlascopco.com

We reserve the right to change specifications without notice. Photos and illustrations do not always show standard versions of machines. The above information is a general description only, all informations are supplied without liability.