



Cat[®] 301.7D CR

MINI HYDRAULIC EXCAVATOR

FEATURES:

- Compact radius
- Powerful hydraulics
- 2-way auxiliary as standard
- Extending undercarriage
- Excellent service access
- Quick disconnects standard on auxiliary lines

Specifications

Engine

Engine Model	Yanmar 3TNV76	
Rated Net Power @ 2,200 rpm (ISO 9249)	13.2 kW	17.7 hp
Gross Power (ISO 14396)	17.9 kW	24.3 hp
Displacement	1116 cm ³	40 in ³

Weight

Transport Weight with Canopy	1610 kg	3,550 lb
Operating Weight with Canopy	1690 kg	3,726 lb

- Weight includes standard stick, rubber tracks, bucket, operator and full fuel.

Travel System

Travel Speed	2.8 km/h-	1.74 mph-
	5.6 km/h	3.48 mph
Gradeability	30°/58%	

Service Refill Capacities

Fuel Tank Capacity	19 L	5.0 gal
Hydraulic Tank Capacity	20 L	5.3 gal

Blade

Width	990 mm/	3 ft 3 in/
	1300 mm	4 ft 3 in
Height	230 mm	9 in
Dig Depth	390 mm	15 in
Lift Height	271 mm	11 in

Hydraulic System

Pump Flow @ 2,200 rpm	23.8 + 23.8	6.29 + 6.29
	+ 19.0 +	+5.0 +
	6.4 L/min	1.7 gal/min
Operating Pressure – Equipment	200 bar	2,900 psi
Operating Pressure – Travel	200 bar	2,900 psi
Operating Pressure – Swing	150 bar	2,176 psi
Auxiliary Circuits		
Primary and Secondary Auxiliary Circuits		
Maximum Flow	35 L/min	9 gal/min
Maximum Pressure	240 bar	3,480 psi
Maximum Bucket Force	14.2 kN	3,190 lbf
Maximum Stick Force – Standard Stick	8.4 kN	1,890 lbf
Maximum Stick Force – Long Stick	7.3 kN	4,640 lbf

301.7D CR Mini Hydraulic Excavator

Lift Capacity at Ground Level – Undercarriage Extended

Lift Point Radius	2 m (6'7")				2.5 m (8'2")				3 m (9'10")				Maximum			
	Front		Side		Front		Side		Front		Side		Front		Side	
	kg	lb	kg	lb	kg	lb	kg	lb	kg	lb	kg	lb	kg	lb	kg	lb
Standard Stick/Extended Undercarriage/Blade Down	*916	*2,020	376	830	*653	*1,440	271	598	*493	*1,087	208	456	*404	*890	179	395
Long Stick/Extended Undercarriage/Blade Down	*929	*2,048	373	822	*655	*1,444	269	593	*497	*1,096	206	454	*380	*838	165	364

Machine fitted with standard dozer blade and standard counterweight.

The above loads are in compliance with hydraulic excavator lift capacity rating standard ISO 10567:2007 and they do not exceed 87% of hydraulic lift capacity or 75% of tipping capacity.

The excavator bucket weight is not included on this chart.

*Loads are hydraulic limited.

STANDARD EQUIPMENT

- Extending undercarriage
- Standard stick
- 230 mm rubber track
- Dozer blade
- Working light mounted to boom
- Canopy – ROPS and TOPS protection
- Retractable seat belt
- Suspension seat, vinyl covered
- Travel steering bars
- Maintenance free battery
- Hydraulic oil cooler
- Hammer/2 way lines

OPTIONAL EQUIPMENT

- Suspension seat, fabric covered
- Boom stick or dozer blade check valve
- Mirror pack
- Top cab guard to ISO 10262 (Level 1)
- Long stick
- Front and rear lights
- 2nd auxiliary lines with flow adjust
- Operator rear weather cover

301.7D CR Mini Hydraulic Excavator

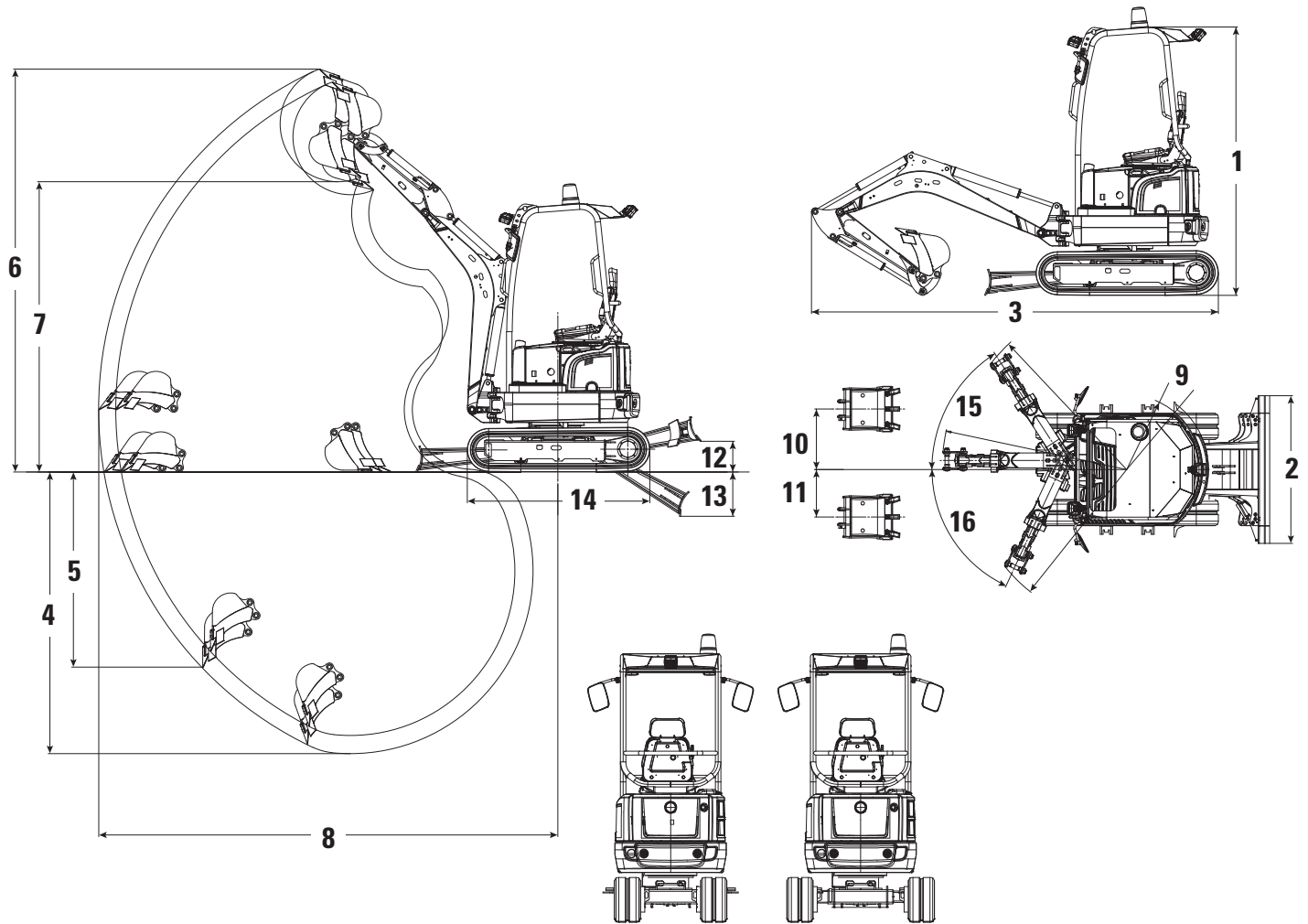

Dimensions (All dimensions are approximate.)

	Standard Stick		Long Stick	
	mm	ft/in	mm	ft/in
1 Height	2362 mm	7'9"	2362 mm	7'9"
2 Width	990 mm-1300 mm	3'3"-4'3"	990 mm-1300 mm	3'3"-4'3"
3 Transport length (arm lowered)	3584 mm	11'9"	3584 mm	11'9"
4 Maximum digging depth	2321 mm	7'7"	2481 mm	8'2"
5 Maximum vertical dig depth	1578 mm	5'2"	1718 mm	5'8"
6 Maximum dig height	3434 mm	11'3"	3548 mm	11'8"
7 Maximum dump height	2441 mm	8'0"	2555 mm	8'5"
8 Maximum reach at ground level	3842 mm	12'7"	3995 mm	13'1"
9 Tail swing radius	660 mm/722 mm	2'1"/2'4"	660 mm/722 mm	2'1"/2'4"
10 Maximum boom offset (RH)	533 mm	1'9"	533 mm	1'9"
11 Maximum boom offset (LH)	418 mm	1'5"	418 mm	1'5"
12 Maximum dozer lift height	271 mm	11"	271 mm	11"
13 Maximum dozer dig depth	390 mm	1'3"	390 mm	1'3"
14 Length of undercarriage (Extending)	1607 mm	5'3"	1607 mm	5'3"
15 Boom swing angle (RH)		57°		57°
16 Boom swing angle (LH)		65°		65°

301.7D CR Mini Hydraulic Excavator

For more complete information on Cat® products, dealer services, and industry solutions, visit us on the web at www.cat.com

AEHQ7030 (03-13)

© 2013 Caterpillar
All Rights Reserved
Printed in U.S.A.

Materials and specifications are subject to change without notice. Featured machines in photos may include additional equipment. See your Cat dealer for available options.

CAT, CATERPILLAR, SAFETY.CAT.COM, their respective logos, "Caterpillar Yellow" and the "Power Edge" trade dress, as well as corporate and product identity used herein, are trademarks of Caterpillar and may not be used without permission.

