

323E SA

Hydraulic Excavator



Engine

Engine Model	Cat® C6.6 ACERT™
Engine Rated Power – ISO 14396	121 kW (165 hp)

Drive

Maximum Travel Speed	5.9 km/h
Maximum Drawbar Pull	190 kN

Weights

Minimum Weight	24 170 kg
Maximum Weight	25 230 kg

Introduction

Since its introduction in the 1990s, the 300 Series family of excavators has become the industry standard in general, quarry, and heavy construction applications. The all-new E Series and the 323E SA will continue that trend-setting standard.

The 323E SA meets today's European Union Stage IIIB emission standards. It is also built with several new fuel-saving and comfort-enabling features and benefits that will delight owners and operators.

If you are looking for more productivity and comfort less fuel consumption and emissions, and easier and more sensible serviceability, you will find it in the all-new 323E SA and the E Series family of excavators.

The 323E SA is a specific configuration of the 323E hydraulic excavator.

It has a stronger, heavier undercarriage than the 323E, specifically designed for work in severe duty underfoot conditions. The 323E SA has a narrow gauge (shipping width 2500 mm) for easy transport, and is intended for work requiring an extra rugged undercarriage (such as mountainous areas).

All other technical aspects of the 323E SA are similar to the 323E L.



Contents

Engine	3
Operator Station.....	4
Hydraulics	5
Structures & Undercarriage	6
Front Linkage	7
Work Tools.....	8
Integrated Technologies.....	10
Serviceability	11
Safety	12
Complete Customer Care.....	13
Sustainability	14
Specifications.....	15
Standard Equipment.....	25
Optional Equipment.....	26
Notes.....	27

The engine of the 323E SA, like the 323E, runs on ultra-low-sulfur diesel fuel (< 15 mg/kg Sulfur) and the fuel system includes a new high-pressure pump, electric priming pump (lifting pump), injectors, and high-durability fuel lines to enable the use of bio fuels up to B20 (biodiesel fuel 20% mixture meeting ASTM 6751 or EN 14214) without reducing the life of the system. Cat® DEO-ULS™ or oils that meet the Cat ECF-3, API CJ-4, and ACEA E9 specification are required. For further fluid specifications and guidelines, visit: <http://www.cat.com/cda/files/214956/7/SEBU6251-13-secured.pdf>

Engine

Reduced emissions, economical and reliable performance

Cat® C6.6 ACERT™ Engine

The Cat C6.6 ACERT engine delivers more horsepower using significantly less fuel than the previous series engine.

Emissions Solution

Equipped to meet Stage IIIB emissions standards, the 323E SA's C6.6 ACERT engine features wall and thru flow filters that perform through the machine work cycle without operator intervention.

All nonroad European Union Stage IIIB diesel engines are required to use only Ultra Low Sulfur Diesel (ULSD) fuels containing 15 mg/kg sulfur or less. Cat® DEO-ULS™ or oils that meet the Cat ECF-3, API CJ-4, and ACEA E9 specification are also required. For further fluid specifications and guidelines, visit: <http://www.cat.com/cdal/files/214956/71/SEBU6251-13-secured.pdf>

Biodiesel-Ready Fuel System

The C6.6 ACERT engine is equipped with an electronic-controlled high-pressure fuel system that includes an electric priming pump (lifting pump) and three-layer fuel hoses to allow the use of biodiesels up to B20 (biodiesel fuel 20% mixture meeting ASTM 6751 or EN 14214).

Cooling System

The cooling system features movable A/C condenser and ATAAC (Air To Air After Cooler) for easy cleaning; the fan automatically adjusts to ambient temperatures to help reduce fuel consumption and noise.

Speed and Power Control

The 323E SA features speed control to maintain a constant speed – regardless of load – to improve fuel economy. Three different power modes are offered: high power, standard power, and economy power. The operator can easily change between modes through the monitor or console switch to meet the needs for the job at hand – all to help manage and conserve fuel.



Operator Station

Comfort and convenience to keep people productive



Seats

The seat range includes air suspension, heated, air cooled and ventilator options. All seats include a reclining back, upper and lower seat slide adjustments, and height and tilt angle adjustments to meet operator needs for comfort and productivity.

Controls

The right and left joystick consoles can be adjusted to meet individual preferences, improving operator comfort and productivity during the course of a day. With the touch of a button, one-touch idle reduces engine speed to help save fuel; touch it again or move the joystick and the machine returns to normal operating level. The heavy lift mode increases machine system pressure to improve lift – a nice benefit in lift applications.

Monitor

The 323E SA is equipped with a 7" LCD (Liquid Crystal Display) monitor that's 40% bigger than the previous model's with higher resolution for better visibility. In addition to an improved keypad and added functionality, it's programmable to provide information in a choice of 42 languages to support today's diverse workforce.

An "Engine Shutdown Setting" accessible through the monitor allows owners and operators to specify how long the machine should idle before shutting down the engine, which can save significant amounts of fuel. The image of the rearview camera is displayed directly on the monitor. Up to two different camera images can be displayed on the screen at the same time.

Power Supply

Two 12-volt power supply sockets are located near key storage areas for charging electronic devices.

Storage

Storage spaces are located in the front, rear, and side consoles. A specific space near the auxiliary power supply holds MP3 players and cell phones. The drink holder accommodates large mugs with handles, and a shelf behind the seat stores large lunch or toolboxes.

Automatic Climate Control

The climate control system features five air outlets with positive filtered ventilation, which makes working in the heat and cold much more pleasant.





Hydraulics

Power to move more dirt, rock, and debris with speed and precision

Main Control Valve and Auxiliary Valves

The 323E SA uses a high-pressure system to tackle the toughest of work in short order. The machine features a highly efficient and simple back-to-back main control valve to improve fuel consumption; it also allows for greater tool versatility.

Swing Priority Circuit

The swing priority circuit on the 323E SA uses an electric valve that's operated by the machine's Electronic Control Module (ECM). Compared to using a hydraulic valve, an electric valve allows for more finely tuned control, which is critical during material loading.

SmartBoom™

SmartBoom reduces stress and vibrations transmitted to the machine and provides a more comfortable environment. It is particularly well suited for certain applications:

- **Rock scraping.** SmartBoom simplifies the task and allows the operator to concentrate on stick and bucket while the boom freely goes up and down without using pump flow.
- **Hammer work.** The front parts automatically follow the hammer while penetrating the rock. Blank shots or excessive force on the hammer are avoided, resulting in longer life for the hammer and the machine.

Electric Boom Regeneration Valve

This valve minimizes pump flow when the boom lowers down, which helps improve fuel efficiency. It is optimized for any dial speed setting being used by the operator, which results in optimized boom lowering speed for higher controllability.



Structures & Undercarriage

Built to work in rugged environments

Frame

The upper frame includes reinforced mountings to support the Roll-Over Protective Structure (ROPS) cab; the lower frame is reinforced to increase component durability.

Undercarriage

Fixed gauge long narrow undercarriage system is available to support various work applications.

Center or full length track guiding guard is now offered to help maintain track alignment and improve performance in multiple applications.

Counterweights

The machine comes equipped with a 4.4 mt counterweight with integrated rearview camera housing. The counterweight also features integrated links to enable easy removal for maintenance or shipping.

Front Linkage

Made for high stress and long service life

Booms and Sticks

The 323E SA can be equipped with a 5.7 m reach ES (extreme service) boom, 5.7 m reach HD (heavy duty) or VA (variable angle) boom. The available sticks are R2.9B1 ES, R2.5B1 ES and R1.9CB2 HD.

Both booms and sticks are made of high-tensile-strength steel using a large box section design with interior baffle plates and an additional bottom guard; both undergo ultrasound inspection to ensure weld quality and reliability.



Work Tools

Dig, hammer, rip, and cut with confidence



An extensive range of Cat Work Tools for the 323E SA includes buckets, compactors, grapples, multi-processors, scrap and demolition shears, rippers, crushers, pulverizers, hammers, and shears. Each is designed to optimize the versatility and performance of your machine.

CW Quick Couplers

Quick couplers allow one person to change work tools in seconds for maximum performance and flexibility on a job site. One machine can move rapidly from task to task, and a fleet of similarly equipped machines can share a common work tool inventory. The dedicated CW Series quick coupler enables a quick tool exchange while maintaining top machine performance. A lifting hook is added for maximum lift capacity.

The CW quick coupler can pick up any work tool and is equipped with a wedge-style locking system that fits the quick coupler tight to the tool hinges. Due to the tapered wedge design, there won't be any play during its entire life. Also, it is interchangeable with different machine classes. The CW is highly suitable for harsh applications such as demolition and quarries.

Buckets

Cat buckets are designed as an integral part of the 323E SA system and feature new geometry for better performance. The leading edge has been pushed forward, resulting in more efficient filling and better operator control for greatly improved productivity. Wear coverage in the corners and side cutter and sidebar protector coverage are improved. All benefits are captured in a new bucket line with a new bucket naming convention.

Durability Categories Suitable for Any Situation

For the 323E SA excavator, Caterpillar offers three standard bucket categories for excavators. Each category is based on intended bucket durability when used in recommended application and material. Each bucket durability is available as pin-on or can be used with a Quick Coupler. Red areas on bucket images illustrate additional protection against wear as it increases across each category.

General Duty (GD)

GD buckets are for digging in low-impact, low-abrasion material such as dirt, loam, and mixed compositions of dirt and fine gravel.

Heavy Duty (HD)

The most popular bucket style, HD buckets are a good starting point when digging conditions are not well known like a wide range of impact and abrasion conditions that include mixed dirt, clay, and rock.

Severe Duty (SD)

SD buckets are for higher abrasion conditions such as well shot granite and caliche.

Special Buckets

Special buckets are available for the 323E SA on request.

Comprehensive Product Support

All Cat Work Tools are backed up by a world-wide network of well-stocked parts depots and highly experienced service and support personnel.

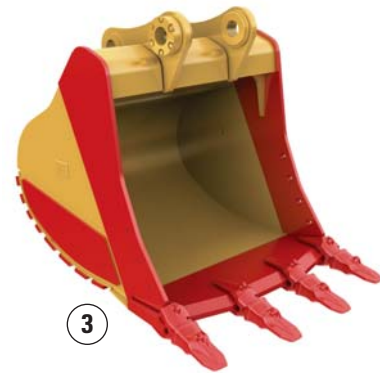
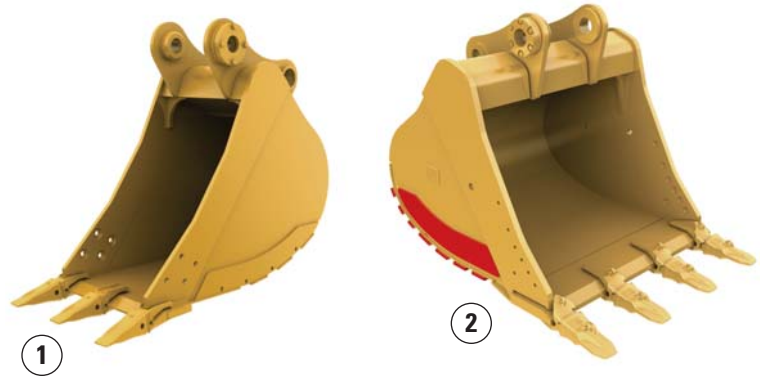

1) General Duty 2) Heavy Duty 3) Severe Duty



Integrated Technologies

Solutions that make work easier and more efficient

Cat® Grade Control Depth and Slope

This optional system combines traditional machine control and guidance with standard factory-installed and calibrated components, making the system ready to go to work the moment it leaves the factory. The system utilizes internal front linkage sensors – well protected from the harsh working environment – to give operators real-time bucket tip position information through the cab monitor (1), which minimizes the need and cost for traditional grade checking and improves job site safety. It also helps the operator complete jobs in fewer cycles, which means less fuel use. Cat dealers can upgrade the system to full three-dimensional control by adding proven Cat AccuGrade™ positioning technologies, including GPS and Universal Total Station (UTS).

Cat Product Link

This deeply integrated machine monitoring system (2 and 3) is designed to help customers improve their overall fleet management effectiveness. Events and diagnostic codes as well as hours, fuel consumption, idle time, machine location, and other detailed information are transmitted to a secure web based application called VisionLink™, which uses powerful tools to communicate to users and dealers.

Serviceability

Fast, easy and safe access built in

Service Doors

Wide service doors and a one-piece hood provide easy access to the engine and cooling compartments. Both doors and hood feature enhanced hardware and a new screen design to help minimize debris entry.

Compartments

The radiator, pump, and air cleaner compartments provide easy access to major components. The fresh air filter is located on the side of the cab to make it easy to reach and replace as needed.

Maintenance

Tilt-up ATAAC and swing out A/C condenser for easy cleaning.

Other Service Benefits

The water separator with water level sensor has a primary fuel filter element located in the pump compartment near ground level; the electric priming pump (lifting pump) is mounted before the primary filter.

The fuel tank features a remote drain cock located in the pump compartment to make it easy to remove water and sediment during maintenance.

The engine oil check gauge is situated in front of the engine compartment for easy access, and a uniquely designed drain cock helps prevent spills. The engine oil filter is located in the pump compartment.

The hydraulic valve lush located on the engine valve does not need maintenance.



Safety

Features to help protect people



ROPS Cab (ISO 12117)

The ROPS-certified cab allows a Falling Object Guard Structure (FOGS) to be bolted directly to it.

Sound Proofing

Improved sealing and cab roof lining lower noise levels inside the cab significantly during machine operation (-5 dB).

Anti-Skid Plates

The surface of the upper structure and the top of the storage box area are covered with anti-skid plates to help prevent service personnel and operators from slipping during maintenance.

Steps, Hand and Guard Rails (ISO 2867)

Steps on the track frame and storage box along with extended hand and guard rails (2) to the upper deck enable operators to securely work on the machine.

Time Delay Lights

After the engine start key has been turned to the “OFF” position, cab and boom lights will illuminate to enhance visibility. The time delay can vary from 0 to 90 seconds, which can be set through the cab monitor.

High Intensity Discharge (HID) Lights

Halogen lights are standard, but they can be upgraded to HID for greater visibility.

Visibility – Windows

Two windshield options are available: The 70/30 split windshield configuration features an upper window equipped with handles on the top and both sides so the operator can slide it to store in the ceiling. The lower window is removable and can be stored on the left wall of the cab shell.

The large skylight provides great overhead visibility, excellent natural lighting, and good ventilation. The skylight can be opened completely to become an emergency exit.

Monitor Warning System

The monitor is equipped with a buzzer that can warn operators of critical events so they can take any necessary action.

Rearview Camera and Mirrors (ISO 5006)

The standard rearview camera is housed in the counterweight. The image projects through the cab monitor to give the operator a clear view of what is behind the machine. The mirrors and rearview camera are designed to meet visibility regulations.



Complete Customer Care

Service you can count on

Product Support

Cat dealers utilize a worldwide parts network to maximize your machines' uptime. Plus they can help you save money with Cat remanufactured components.

Machine Selection

What are the job requirements and machine attachments? What production is needed? Your Cat dealer can provide recommendations to help you make the right machine choices.

Purchase

Consider financing options and day-to-day operating costs. Look at dealer services that can be included in the machine's cost to yield lower owning and operating costs over time.

Customer Support Agreements

Cat dealers offer a variety of customer support agreements and work with you to develop a plan to meet your specific needs. These plans can cover the entire machine, including attachments, to help protect your investment.

Operation

Improving operating techniques can boost your profits. Your Cat dealer has videos, literature, and other ideas to help you increase productivity. Caterpillar also offers simulators and certified operator training to help maximize the return on your investment.

Replacement

Repair, rebuild, or replace? Your Cat dealer can help you evaluate the cost involved so you can make the best choice for your business.



Sustainability

Generations ahead in every way

- The C6.6 ACERT engine, along with the Cat Clean Emissions Module (CEM), meets EU Stage IIIB emission standards.
- Even when operating in high horsepower and high production applications, the 323E SA performs a similar amount of work while burning up to 12% less fuel than the previous D Series model. This means more efficiency, less resources consumed, and fewer CO₂ emissions.
- The 323E SA has the flexibility of running on either ultra-low-sulfur diesel (ULSD) fuel with 15 mg/kg of sulfur or less or bio diesel (B20) fuel blended with ULSD.
- A ground-level overfill indicator rises when the hydraulic oil tank is full to help the operator avoid spilling.
- The 323E SA is built to be rebuilt with major structures and components capable of being remanufactured to reduce waste and replacement costs.
- An engine oil filter is designed so that it eliminates the need for painted metal cans and aluminum top plates. The cartridge-style spin-on housing enables the internal filter to be separated and replaced.
- The 323E SA is an efficient, productive machine that's designed to conserve our natural resources for generations ahead.

323E SA Hydraulic Excavator Specifications

Engine

Engine Model	Cat® C6.6 ACERT™
Engine Rated Power – ISO 14396	121 kW
Engine Rated Power – ISO 14396 (metric)	165 hp
Engine Rated Power – ISO 14396 (imperial)	162 hp
Bore	105 mm
Stroke	127 mm
Displacement	6.6 L

Weights

Minimum Weight	24 170 kg
Maximum Weight	25 230 kg

Hydraulic System

Main System – Maximum Flow (Total)	428 L/min
Swing System – Maximum Flow	214 L/min
Maximum Pressure – Equipment	35 000/38 000 kPa
Maximum Pressure – Travel	35 000 kPa
Maximum Pressure – Swing	25 000 kPa
Pilot System – Maximum Flow	24.3 L/min
Pilot System – Maximum Pressure	3920 kPa
Boom Cylinder – Bore	120 mm
Boom Cylinder – Stroke	1260 mm
Stick Cylinder – Bore	140 mm
Stick Cylinder – Stroke	1504 mm
B1 Bucket Cylinder – Bore	120 mm
B1 Bucket Cylinder – Stroke	1104 mm

Drive

Maximum Travel Speed	5.9 km/hr
Maximum Drawbar Pull	190 kN

Swing Mechanism

Swing Speed	11.5 rpm
Swing Torque	61.8 kN·m

Service Refill Capacities

Fuel Tank Capacity	310 L
Cooling System	30 L
Engine Oil (with filter)	23 L
Swing Drive	8 L
Final Drive (each)	8 L
Hydraulic System (including tank)	260 L
Hydraulic Tank	135 L

Track

Number of Shoes (each side)	45 pieces
Number of Track Rollers (each side)	7 pieces
Number of Carrier Rollers (each side)	2 pieces

Sound Performance

ISO 6396	
Operator Sound	71 dB(A)

ISO 6395	
Spectator Sound	103 dB(A)

- Operator Sound – The operator sound level is measured according to the procedures specified in ISO 6394:1998, for cab offered by Caterpillar, when properly installed and maintained and tested with doors and windows closed.
- Exterior Sound – The labeled spectator sound power level is measured according to the test procedures and conditions specified in 2004/14/EC.
- Hearing protection may be needed when operating with an open operator station and cab (when not properly maintained for doors/windows open) for extended periods or in a noisy environment.

Standards

Brakes	ISO 10265 2008
Cab/FOGS	ISO 10262 1998
Cab/ROPS	ISO 12117-2 2008

323E SA Hydraulic Excavator Specifications

323E SA Dimensions

All dimensions are approximate.

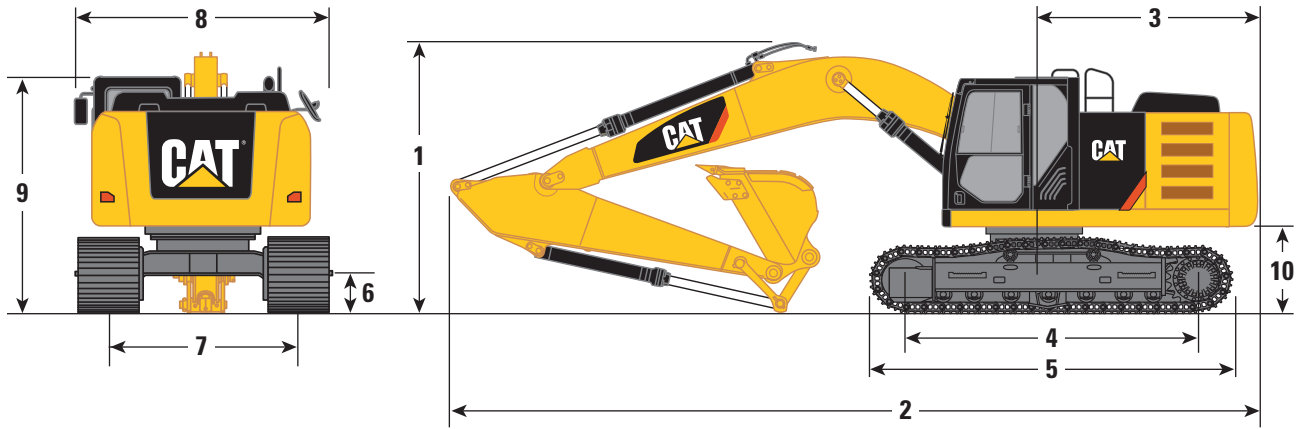

Stick	Reach Boom 5.7 m		VA Boom	
	R2.9B1	R2.5B1	R1.9CB2	R2.5B1
	mm	mm	mm	mm
1 Shipping Height without Guard Rail*	3100	3100	3200	3060
Shipping Height with Guard Rail	3320	3320	3320	3320
Shipping Height with Top Guard, without Guard Rail	3230	3230	3230	3230
2 Shipping Length	9570	9570	9840	9820
3 Tail Swing Radius	2830	2830	2830	2830
4 Length to Center of Rollers				
Special Alpine Undercarriage	3490	3490	3490	3490
5 Track Length				
Special Alpine Undercarriage	4360	4360	4360	4360
6 Ground Clearance				
Long Undercarriage				
Special Alpine Undercarriage	480	480	480	480
7 Track Gauge				
Special Alpine Undercarriage	1900	1900	1900	1900
8 Transport Width				
Special Alpine Undercarriage				
550 mm shoes for SA	2540	2540	2540	2540
9 Cab Height	3030	3030	3030	3030
Cab Height with Top Guard	3230	3230	3230	3230
10 Counterweight Clearance**	1090	1090	1090	1090

*Including shoe lug height.

**Without shoe lug height.

323E SA Working Ranges

All dimensions are approximate.

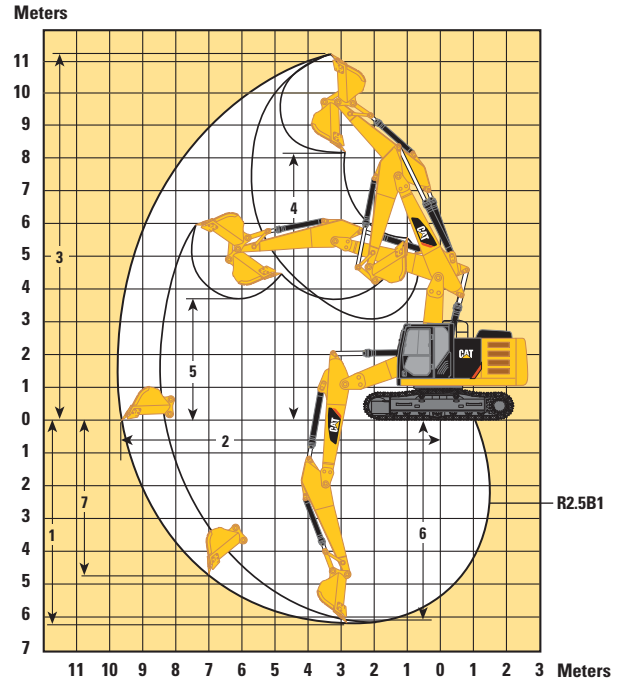
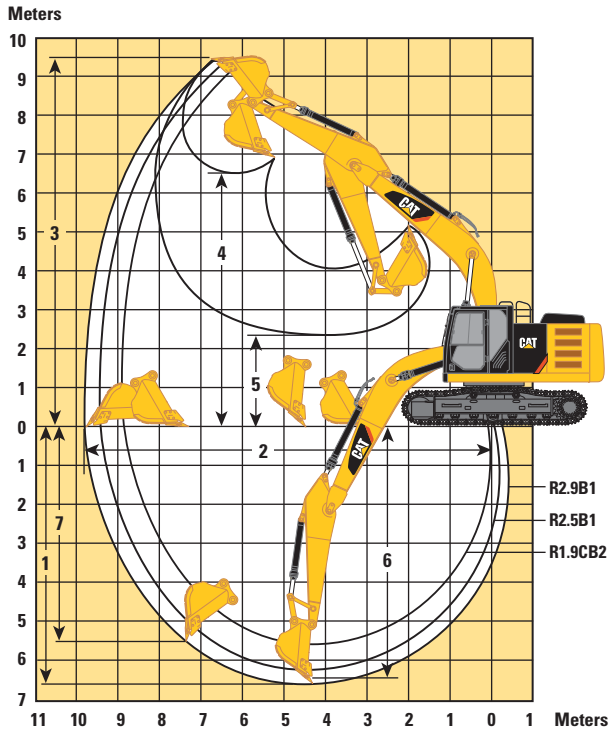

Stick	Reach Boom 5.7 m			VA Boom
	R2.9B1	R2.5B1	R1.9CB2	R2.5B1
	mm	mm	mm	mm
1 Maximum Digging Depth	6640	6220	5680	6200
2 Maximum Reach at Ground Level	9840	9440	8930	9780
3 Maximum Cutting Height	9520	9320	9010	11 250
4 Maximum Loading Height	6580	6370	6000	8140
5 Minimum Loading Height	2260	2680	3220	3740
6 Maximum Depth Cut for 2440 mm Level Bottom	6470	6030	5450	6100
7 Maximum Vertical Wall Digging Depth	5540	5140	4350	4820

323E SA Hydraulic Excavator Specifications

323E SA Operating Weight and Ground Pressure

	550 mm Triple Grouser Shoes	
	kg	kPa
Reach Boom HD – 5.7 m		
R2.9B1 ES	24 270	65.0
R2.5B1 ES	24 170	64.8
R1.9CB2 HD	24 170	64.8
Reach Boom ES – 5.7 m		
R2.5B1 ES	24 460	65.5
VA Boom		
R2.5B1 ES	25 230	67.4

323E SA Major Component Weights

	kg
Base Machine (with boom cylinder, without counterweight, front linkage and track)	12 240
Long Undercarriage with 550 mm Triple Grouser	8340
Counterweight	
4.4 mt	4400
Boom (includes lines, pins and stick cylinder)	
Reach Boom HD – 5.7 m	1720
Reach Boom ES – 5.7 m	2010
VA Boom	2580
Stick (includes lines, pins and bucket cylinder)	
R2.9B1 ES	840
R2.5B1 ES	770
R1.9 CB2	740
Track Shoe (Long/per two tracks)	
550 mm Triple Grouser	3090
Quick Coupler	
Dedicated	250

All weights are rounded up to nearest 10 kg except for quick coupler and buckets.

Base machine includes 75 kg operator weight, 90% fuel weight, and undercarriage with center guard.

323E SA Bucket and Stick Forces

Stick	Reach Boom 5.7 m		VA Boom	
	B1-Family Bucket		CB2-Family Bucket	B1-Family Bucket
	R2.9B1	R2.5B1	R1.9CB2	R2.5B1
	kN	kN	kN	kN
General Duty				
Bucket Digging Force (ISO)	140.5	140.5	178.9	140.5
Stick Digging Force (ISO)	106.7	118.2	147.9	118.2
General Duty Capacity				
Bucket Digging Force (ISO)	139.4	139.4	174.1	139.4
Stick Digging Force (ISO)	106.2	117.7	145.5	117.7
Heavy Duty				
Bucket Digging Force (ISO)	140.2	140.2	178.7	140.2
Stick Digging Force (ISO)	106.6	118.1	147.8	118.1
Heavy Duty – Power				
Bucket Digging Force (ISO)	–	–	194.9	–
Stick Digging Force (ISO)	–	–	149.7	–
Severe Duty				
Bucket Digging Force (ISO)	–	–	178.5	–
Stick Digging Force (ISO)	–	–	147.7	–
B1-Family Bucket for CW-40				
	B1-Family Bucket		CB2-Family Bucket	B1-Family Bucket
General Duty				
Bucket Digging Force (ISO)	127.7	127.7	162.9	127.7
Stick Digging Force (ISO)	103.2	114.0	140.6	114.0
Heavy Duty				
Bucket Digging Force (ISO)	127.4	127.4	–	127.4
Stick Digging Force (ISO)	103.1	113.8	–	113.8
B1-Family Bucket for CW-40S				
	B1-Family Bucket		CB2-Family Bucket	B1-Family Bucket
General Duty				
Bucket Digging Force (ISO)	127.7	127.7	–	127.7
Stick Digging Force (ISO)	103.2	114.0	–	114.0
Heavy Duty				
Bucket Digging Force (ISO)	127.4	127.4	171.8	127.4
Stick Digging Force (ISO)	103.1	113.8	144.8	113.8

323E SA Hydraulic Excavator Specifications

323E SA Reach Boom Lift Capacities



Load Point Height



Load at Maximum Reach



Load Radius Over Front















Load Radius Over Side

Boom – 5.7 m HD
Stick – R2.5B1 ES

Counterweight – 4.4 mt
Shoes – 550 mm triple grouser, Alpine shoe













Bucket – None
Heavy Lift – On

		3.0 m		4.5 m		6.0 m		7.5 m				
												m
7.5 m	kg									*5050	*5050	5.67
6.0 m	kg					*5750	5050			*4650	4000	6.87
4.5 m	kg			*7350	*7350	*6250	4900	*5350	3450	*4550	3350	7.59
3.0 m	kg			*9200	6900	*7100	4650	6050	3350	*4700	3050	7.97
1.5 m	kg			*10 800	6450	*7900	4400	5900	3250	*5000	2950	8.05
Ground Line	kg			*11 450	6200	8050	4250	5850	3150	5500	3000	7.84
-1.5 m	kg	*12 250	11 300	*11 250	6150	7950	4200			6050	3250	7.32
-3.0 m	kg	*14 000	11 500	*10 150	6250	*7500	4250			*6750	3950	6.40
-4.5 m	kg			*7350	6500					*6550	5850	4.88

Boom – 5.7 m ES
Stick – R2.5B1 ES

Counterweight – 4.4 mt
Shoes – 550 mm triple grouser, Alpine shoe

Bucket – None
Heavy Lift – On

		3.0 m		4.5 m		6.0 m		7.5 m				
												m
7.5 m	kg									*5050	*5050	5.67
6.0 m	kg					*5700	5000			*4650	4000	6.87
4.5 m	kg			*7250	*7250	*6200	4850	*5350	3400	*4550	3300	7.59
3.0 m	kg			*9100	6800	*7000	4600	6000	3300	*4700	3000	7.97
1.5 m	kg			*10 650	6300	*7750	4300	5850	3200	*5000	2850	8.05
Ground Line	kg			*11 300	6050	7950	4150	5750	3100	5450	2900	7.84
-1.5 m	kg	*12 250	11 050	*11 050	6000	7900	4100			5950	3200	7.32
-3.0 m	kg	*13 750	11 250	*10 000	6100	*7350	4150			*6650	3850	6.40
-4.5 m	kg			*7200	6400					*6400	5750	4.88

*Indicates that the load is limited by hydraulic lifting capacity rather than tipping load. The above loads are in compliance with hydraulic excavator lift capacity standard ISO 10567:2007. They do not exceed 87% of hydraulic lifting capacity or 75% of tipping load. Weight of all lifting accessories must be deducted from the above lifting capacities. Lifting capacities are based on the machine standing on a firm, uniform supporting surface. The use of a work tool attachment point to handle/lift objects, could affect the machine lift performance.

Always refer to the appropriate Operation and Maintenance Manual for specific product information.

323E SA Reach Boom Lift Capacities



Load Point Height



Load at Maximum Reach



Load Radius Over Front

















Load Radius Over Side

Boom – 5.7 m HD
Stick – R2.9B1 ES

Counterweight – 4.4 mt
Shoes – 550 mm triple grouser, Alpine shoe











Bucket – None
Heavy Lift – On

		1.5 m		3.0 m		4.5 m		6.0 m		7.5 m				m
														
7.5 m	kg							*5100	5100			*4200	*4200	6.22
6.0 m	kg							*5300	5100			*3900	3650	7.33
4.5 m	kg							*5850	4950	*5500	3500	*3850	3100	8.01
3.0 m	kg					*8600	7000	*6750	4700	*5850	3350	*3900	2850	8.36
1.5 m	kg					*10 350	6500	*7600	4400	5900	3250	*4150	2750	8.44
Ground Line	kg			*6750	*6750	*11 300	6200	8000	4250	5800	3150	*4650	2750	8.24
-1.5 m	kg	*7250	*7250	*11 600	11 100	*11 350	6100	7900	4150	5750	3100	*5450	3000	7.75
-3.0 m	kg	*12 300	*12 300	*14 900	11 300	*10 550	6150	*7800	4200			*6450	3500	6.89
-4.5 m	kg			*11 700	11 650	*8400	6350					*6450	4900	5.51

Boom – 5.7 m HD
Stick – R1.9CB2 HD

Counterweight – 4.4 mt
Shoes – 550 mm triple grouser, Alpine shoe

Bucket – None
Heavy Lift – On

		3.0 m		4.5 m		6.0 m				m
										
7.5 m	kg							*6800	*6800	4.83
6.0 m	kg					*6400	4850	*6400	4600	6.20
4.5 m	kg			*8050	7200	*6700	4700	*6350	3700	7.00
3.0 m	kg			*9900	6600	*7400	4500	6050	3300	7.40
1.5 m	kg			*11 150	6200	8050	4300	5850	3200	7.49
Ground Line	kg			*11 350	6050	7950	4150	6050	3250	7.26
-1.5 m	kg	*12 750	11 400	*10 800	6100	7900	4150	6800	3650	6.69
-3.0 m	kg	*12 150	11 550	*9250	6250			*7050	4600	5.68

*Indicates that the load is limited by hydraulic lifting capacity rather than tipping load. The above loads are in compliance with hydraulic excavator lift capacity standard ISO 10567:2007. They do not exceed 87% of hydraulic lifting capacity or 75% of tipping load. Weight of all lifting accessories must be deducted from the above lifting capacities. Lifting capacities are based on the machine standing on a firm, uniform supporting surface. The use of a work tool attachment point to handle/lift objects, could affect the machine lift performance.

Always refer to the appropriate Operation and Maintenance Manual for specific product information.

323E SA Hydraulic Excavator Specifications

323E SA Variable Angle Boom Lift Capacities



Boom – Variable Angle

Counterweight – 4.4 mt

Bucket – None

Stick – R2.5B1 ES

Shoes – 550 mm triple grouser, Alpine shoe

Heavy Lift – On

		1.5 m		3.0 m		4.5 m		6.0 m		7.5 m				m
9.0 m	kg											*6100	*6100	4.24
7.5 m	kg					*6850	*6850	*5050	5000			*5000	4800	6.14
6.0 m	kg			*7850	*7850	*6750	*6750	*4750	*4750			*4650	3600	7.26
4.5 m	kg			*10 500	*10 500	*6650	*6650	*4850	4800	*4650	3400	*4550	3050	7.95
3.0 m	kg			*9550	*9550	*6500	*6500	*5200	4500	*5050	3250	*4650	2800	8.31
1.5 m	kg			*6500	*6500	*7850	6200	*5850	4250	*5650	3150	*4900	2700	8.39
Ground Line	kg	*9600	*9600	*6400	*6400	*10 250	6000	*6850	4100	5800	3050	5150	2750	8.18
-1.5 m	kg	*10 950	*10 950	*10 000	*10 000	*9650	5950	*7550	4050	*5450	3050	*5100	3000	7.69
-3.0 m	kg	*16 900	*16 900	*11 900	11 250	*7650	6100	*5550	4150			*4900	3650	6.69
-4.5 m	kg			*12 350	11 750							*9600	8300	3.77

*Indicates that the load is limited by hydraulic lifting capacity rather than tipping load. The above loads are in compliance with hydraulic excavator lift capacity standard ISO 10567:2007. They do not exceed 87% of hydraulic lifting capacity or 75% of tipping load. Weight of all lifting accessories must be deducted from the above lifting capacities. Lifting capacities are based on the machine standing on a firm, uniform supporting surface. VA-cylinder is flexible. The use of a work tool attachment point to handle/lift objects, could affect the machine lift performance.

Always refer to the appropriate Operation and Maintenance Manual for specific product information.

323E SA Work Tool Offering Guide*

Boom Type	Heavy Duty R5.7		Extreme Service R5.7	Variable Angle (VA) Boom
	ES R2.9	ES R2.5	ES R2.9	HD R2.5
Hydraulic Hammer	H115Es H120Es H130Es	H115Es H120Es H130Es	H115Es H120Es H130Es	H115Es H120Es H130Es
Multi-Processor	MP15	MP15	MP15	MP15
Crusher	P315	P315	P315	P315
Pulverizer	P215	P215	P215	P215
Demolition and Sorting Grapple	G315B	G315B G320B†	G315B	G315B
Mobile Scrap and Demolition Shear	S320B† S325B** S340B***	S320B S325B** S340B***	S320B† S325B**	S320B S325B**
Compactor (Vibratory Plate)	CVP110	CVP110	CVP110	CVP110
Contractors' Grapple	G120B-G130B	G120B-G130B	G120B-G130B	G120B-G130B
Rippers	These work tools are available for the 323E. Consult your Cat dealer for proper match.			
Dedicated Quick Coupler				

*Matches are dependent on excavator configurations. Consult your Cat dealer for proper work tool match.

†Pin-on only.

**Boom mount.

***Boom mount, use over the front only.

323E SA Hydraulic Excavator Specifications

323E SA Bucket Specifications and Compatibility

	Linkage	Width	Capacity	Weight	Fill	Reach Boom (HD)			Reach Boom (ES)	VA Boom
		mm	m ³	kg	%	R2.9 ES	R2.5 ES	R1.9 CB HD	R2.5 ES	R2.5 ES
Without Quick Coupler										
General Duty (GD)	B	600	0.46	549	100%	●	●		●	●
	B	750	0.64	620	100%	●	●		●	●
	B	900	0.81	666	100%	●	●		●	●
	B	1200	1.19	800	100%	⊖	⊙		⊙	⊙
	B	1300	1.30	832	100%	⊖	⊖		⊖	⊖
	B	1400	1.43	867	100%	○	⊖		⊖	⊖
Heavy Duty (HD)	B	1050	1.00	879	100%	⊙	●		●	●
	B	1200	1.19	906	100%	⊖	⊙		⊖	⊖
	B	1200	1.19	917	100%	⊖	⊙		⊖	⊖
	B	1300	1.30	960	100%	○	⊖		⊖	⊖
Severe Duty (SD)	B	1200	1.19	1000	90%	⊖	⊙		⊙	⊙
Super Long Reach (SLR)	SLR	813	0.46	341	100%					
	SLR	1143	0.61	289	100%					
Maximum load pin-on (payload + bucket)					kg	2790	3030	3370	2940	2930
With Quick Coupler (CW40, CW40s)										
General Duty (GD)	B	600	0.46	502	100%	●	●		●	●
	B	750	0.64	587	100%	●	●		●	●
	B	900	0.81	653	100%	●	●		●	●
	B	1200	1.19	767	100%	⊖	⊖		⊖	⊖
	B	1300	1.30	798	100%	○	⊖		⊖	⊖
	B	1400	1.43	834	100%	○	○		○	○
Heavy Duty (HD)	B	600	0.46	584	100%	●	●		●	●
	B	1200	1.19	873	100%	○	⊖		⊖	⊖
	B	1300	1.30	927	100%	○	○		○	○
Severe Duty (SD)	B	1200	1.19	984	90%	⊖	⊖		⊖	⊖
Maximum load with coupler (payload + bucket)					kg	2538	2778	3118	2688	2678

The above loads are in compliance with hydraulic excavator standard EN474, they do not exceed 87% of hydraulic lifting capacity or 75% of tipping capacity with front linkage fully extended at ground line with bucket curled.

Capacity based on ISO 7451.

Bucket weight with General Duty tips.

Maximum Material Density:

- 2100 kg/m³
- ⊙ 1800 kg/m³
- ⊖ 1500 kg/m³
- 1200 kg/m³

Caterpillar recommends using appropriate work tools to maximize the value customers receive from our products. Use of work tools, including buckets, which are outside of Caterpillar's recommendations or specifications for weight, dimensions, flows, pressures, etc. may result in less-than-optimal performance, including but not limited to reductions in production, stability, reliability, and component durability. Improper use of a work tool resulting in sweeping, prying, twisting and/or catching of heavy loads will reduce the life of the boom and stick.

Standard equipment may vary. Consult your Cat dealer for details.

ENGINE

- C6.6 diesel engine
- Biodiesel capable
- European Union Stage IIIB compliant
- 2300 m altitude capability
- Electric priming pump (lifting pump)
- Automatic engine speed control
- Economy and high power modes
- Two-speed travel
- Side-by-side cooling system (tilt-up ATAAC, swing-out A/C condenser)
- Radial seal air filter
- Primary filter with water separator and water separator indicator switch
- Starting kit, cold weather, -18° C
- Screen fuel filter in fuel lines
- Primary fuel filter
- Secondary fuel filter
- Electric refueling pump with auto shut off

HYDRAULIC SYSTEM

- Regeneration circuit for boom and stick
- Reverse swing dampening valve
- Automatic swing parking brake
- High-performance hydraulic return filter
- Capability of installing HP stackable valve and medium and QC valve
- Capability of installing additional auxiliary pump and circuit
- Capability of installing boom lowering control device and stick lowering check valve
- Capability of installing Cat Bio hydraulic oil

CAB

- Pressurized operator station with positive filtration
- Mirror package
- Sliding upper door window (left-hand cab door)
- Glass-breaking safety hammer
- Removable lower windshield with in cab storage bracket
- Coat hook
- Beverage holder
- Literature holder
- Two stereo speakers
- Storage shelf suitable for lunch or toolbox
- Color LCD display with warning, filter/fluid change, and working hour information
- Adjustable armrest
- Height adjustable joystick consoles
- Neutral lever (lock out) for all controls
- Travel control pedals with removable hand levers
- Capability of installing two additional pedals
- Two power outlets, 10 amp (total)
- Laminated glass front upper window and tempered other windows
- Sunscreen
- Windshield wiper, lower with washer
- Air pre-filter

UNDERCARRIAGE

- Grease Lubricated Track GLT2, resin seal
- Towing eye on base frame

ELECTRICAL

- 80 amp alternator
- Circuit breaker
- Capability to electrically connect a beacon

LIGHTS

- Boom light with time delay
- Exterior lights integrated into storage box
- Working lights, cab mounted with time delay

SECURITY

- Cat one key security system
- Door locks
- Cap locks on fuel and hydraulic tanks
- Lockable external tool/storage box
- Signaling/warning horn
- Secondary engine shutoff switch
- Openable skylight for emergency exit
- Rearview camera

TECHNOLOGY

- Product Link

323E SA Optional Equipment

Optional equipment may vary. Consult your Cat dealer for details.

ENGINE

Starting kit, cold weather, -32° C
Radiator screen

HYDRAULIC SYSTEM

Additional circuit
Boom and stick lines
High-pressure line
Medium-pressure line
Cat quick coupler line – high- and medium-pressure capable
Electronic Control device, 1/2P, one-way circuit
Electronic Control device (Common), 1/2P, common circuit

CAB

Seat, high-back air suspension with heater
Seat, high-back air suspension with heater and ventilation
Travel alarm
Left foot switch
Straight travel pedal

UNDERCARRIAGE

Guard, full length
Center track guiding guard

FRONT LINKAGE

Quick coupler
Bucket linkage, B1 family with lifting eye
Bucket linkage, CB2 family with lifting eye
5.7 m reach boom – HD and ES
2.5 m extreme service sticks
2.9 m extreme service sticks
1.9 m heavy-duty stick

SECURITY

Cat MSS (anti-theft device)

TECHNOLOGY

Cat Grade Control Depth and Slope

323E SA Hydraulic Excavator

For more complete information on Cat products, dealer services, and industry solutions, visit us on the web at www.cat.com

© 2012 Caterpillar Inc.
All rights reserved

Materials and specifications are subject to change without notice. Featured machines in photos may include additional equipment. See your Cat dealer for available options.

CAT, CATERPILLAR, SAFETY.CAT.COM, their respective logos, "Caterpillar Yellow" and the "Power Edge" trade dress, as well as corporate and product identity used herein, are trademarks of Caterpillar and may not be used without permission.

AEHQ6584-01 (03-2012)
Replaces AEHQ6584
(EU)

