



Cat[®] CS68B

SMOOTH DRUM VIBRATORY SOIL COMPACTOR

FEATURES:

The Cat[®] CS68B features a smooth drum and is ideally suited for granular soil applications:

- **Comfortable and ergonomic operator station** features pivoting seat with integrated multifunction LCD display and control console, outstanding visibility to the front and rear of machine, low sound levels and vibration for greater operator comfort and productivity.
- **World-class propel system** built around the exclusive Cat dual pump propel system, two pumps provide separate dedicated flow to drum drive motor and rear axle motor for exceptional gradeability and traction in forward and reverse. New electronic propel control enables more precise machine control.
- **Virtually maintenance free** due to maintenance-free hitch bearings and extended maintenance intervals for vibratory system and hydraulic system, providing more uptime and lower maintenance costs.
- **Enhanced compaction performance** due to more weight at the drum and greater amplitude. Automated propel and vibratory system functions make it easy to ensure consistent, high quality.
- **Optional Cat[®] Compaction Control** helps the operator determine when compaction has been completed to specification for greater productivity and uniform compaction quality.

Specifications

Engine - Power Train

Engine Model	Cat [®] C4.4 with ACERT™	
Global Emissions	US EPA Tier 4i/EU Stage IIIB	
Gross Power ISO 14396	117 kW	157 hp
Displacement	4.4 L	268.5 in ³
Stroke	127 mm	5 in
Bore	105 mm	4.1 in
Max. Travel Speed (Forward or Reverse)	11.4 km/h	7 mph

Weights

Operating Weight w/ ROPS/FOPS cab	14 325 kg	31,572 lb
w/ padfoot shell kit	15 730 kg	34,662 lb
w/ leveling blade	14 980 kg	33,011 lb
w/ padfoot shell kit and leveling blade	16 380 kg	36,101 lb
Weight at Drum w/ ROPS/FOPS cab	9150 kg	20,164 lb
w/ padfoot shell kit	10 550 kg	23,247 lb
w/ leveling blade	10 105 kg	22,271 lb
w/ padfoot shell kit and leveling blade	11 505 kg	25,354 lb

Vibratory System Specifications

Frequency		
Standard	30.5 Hz	1830 vpm
During Eco-mode Operation	27.7 Hz	1664 vpm
Optional Variable Frequency	23.3-30.5 Hz	1400-1830 vpm
Nominal Amplitude @30.5 Hz (1830 vpm)		
High	2.1 mm	0.083 in
Low	0.98 mm	0.039 in
Centrifugal Force @ 30.5 Hz (1830 vpm)		
Maximum	301 kN	67,600 lb
Minimum	141 kN	31,670 lb
Static Linear Load		
w/ ROPS/FOPS Cab	42.9 kg/cm	240 lbs/in

Service Refill Capacities

Fuel Tank, total capacity	242 L	64 gal
Cooling System	27.8 L	7.3 gal
Engine Oil w/ Filter	11.6 L	3.1 gal
Eccentric Weight Housings	26 L	6.9 gal
Axle and Final Drives	18 L	4.8 gal
Hydraulic Tank (service refill)	50 L	13.2 gal



CS68B Vibratory Soil Compactor

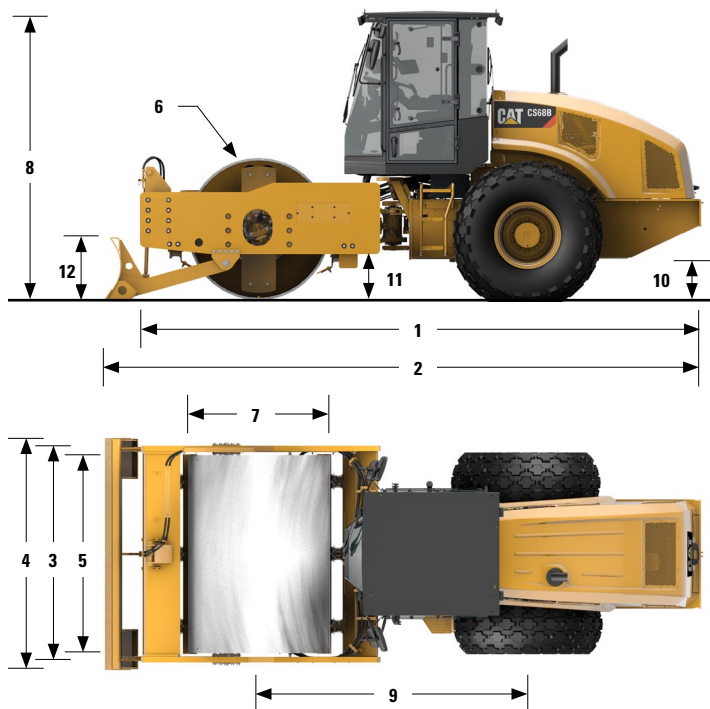

Dimensions

1 Overall Length	6.05 m	19.8 ft
2 Overall Length w/ Optional Leveling Blade	6.55 m	21.5 ft
3 Overall Width	2.33 m	7.64 ft
4 Overall Width w/ Optional Leveling Blade	2.50 m	8.25 ft
5 Drum Width	2134 mm	84 in
6 Drum Shell Thickness	30 mm	1.18 in
7 Drum Diameter	1434 mm	56.5 in
8 Overall Height	3.11 m	10.2 ft
9 Wheelbase	2.9 m	9.5 ft
10 Ground Clearance	437 mm	17.2 in
11 Curb Clearance	489 mm	19.3 in
12 Optional Leveling Blade Height	688 mm	27.1 in
Inside Turning Radius	3.68 m	12.07 ft
Hitch Articulation Angle	34°	
Hitch Oscillation Angle	15°	
Optional Leveling Blade Height	688 mm	27.1 in

STANDARD EQUIPMENT Varies by market- contact your Dealer for specifics.

ELECTRICAL

- 24 volt Electrical System
- 100 ampere Alternator
- 750 Cold-cranking Amps Battery Capacity

OPERATOR ENVIRONMENT

- ROPS/FOPS Cab with Climate Control (Heat, Air Conditioning)
- Cloth Adjustable Pivoting Seat with Integrated Console and LCD Display, Seat Belt
- Multifunction LCD Display with gauges and/or audible warning alarm for: *Hydraulic oil temperature, Engine oil pressure, Engine coolant temperature, Alternator charge, Fuel level, Service hour meter, Engine RPM, Ground speed, Vibe frequency, Fuel rate, Air filter constriction, Engine load and Optional Cat Compaction Control*
- Adjustable Tilting Steering Column with Integrated Cup Holders
- 12-volt Power Outlet
- Floor Mat
- Interior Rear View Mirror
- Horn, Backup Alarm
- Radio-ready

POWER TRAIN

- Cat® C4.4 Diesel Engine
- Air Cleaner, Dual Element
- Three-speed Throttle Switch w/ Eco-mode, Automatic Speed Control
- Dual Propel Pumps; One for Drum Drive, One for Rear Axle
- Fuel Filter, Water Separator, Electronic Priming Pump, Water Indicator
- Tilting Radiator/Hydraulic Oil Cooler
- Dual Braking System
- Two-speed Hydrostatic Transmission

VIBRATORY SYSTEM

- Smooth Drum
- Dual Amplitude, Single Frequency
- Dual Pod-Style Eccentric Weight Housings
- Auto-vibe Function
- Front Adjustable Steel Scraper

OTHER

- Hydraulic Oil Level Sight Gauge
- Radiator Coolant Level Sight Gauge
- Cat® ToughGuard™ Hose
- S-O-SSM Sampling Valves, Engine Oil and Hydraulic Oil

OPTIONAL EQUIPMENT

- Padfoot Shell Kit
- Leveling Blade
- Variable Vibration Frequency
- Beacon, Rotating
- Polyurethane Drum Scrapers
- Steel Rear-side Drum Scraper
- Bio-oil Factory Fill
- Sun Visor
- Deluxe High-back Air-ride Pivoting Seat
- Cat Compaction Control, Machine Drive Power or CMV
- SBAS GNSS Mapping for Cat Compaction Control (RTK available)
- Upgraded Halogen Light Package
- Cab Internal Rear View Mirrors
- Cab Internal Roll-down Sun Screen
- Product Link
- Additional Rear View Mirrors

For more complete information on Cat products, dealer services, and industry solutions, visit us on the web at www.cat.com

QEHQ1560-02 (03-12)

© 2012 Caterpillar
All Rights Reserved
Printed in U.S.A.

Materials and specifications are subject to change without notice. Featured machines in photos may include additional equipment. See your Cat dealer for available options.

CAT, CATERPILLAR, SAFETY.CAT.COM, their respective logos, "Caterpillar Yellow" and the "Power Edge" trade dress, as well as corporate and product identity used herein, are trademarks of Caterpillar and may not be used without permission.

