

F141-4W/ D Wheeled pavers

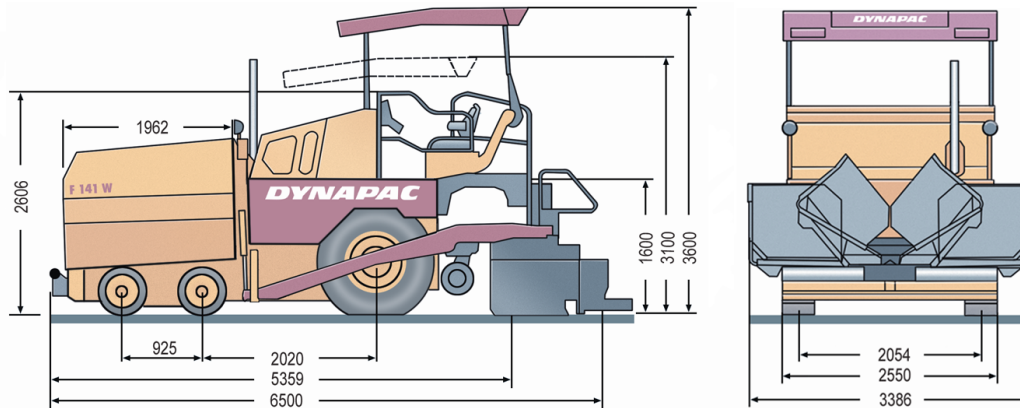

Technical data



Dimensions	F141-4W/ D
Basic width	2.55 m
Working width, hydraulic extendable	5.10 m
Working width, maximum (incl. extension boxes)	7.30 m
Working width, minimum (with reducing shoe)	2 m
Masses	
Weight	17 t
Capacity	
Placement thickness (max)	300 mm
Theoretical placement capacity	750 t/ h
Operation	
Operator console	Shiftable left/ right
Operator seat	Adjustable, comfortable, hydraulically sprung seat
Undercarriage	
Drive wheels	2 x 14.00R-25
Front wheels	4 x 560 / 100-410
Final drive	Hydrostatic, for all functions
Turning radius (inside)	2,800 mm
Material hopper	
Capacity	5.90 m ³
Dumping height, center	520 mm
Dumping height, outside	600 mm
Hopper width, internal	3,386 mm
Traction	
Working speed	0 - 29 m/ min
Transport speed	19.50 km/ h
Conveyor	
Conveyor type	Dual bar feeder
Conveyor width	600 mm
Conveyor control	Proportional speed control, both sides driven independently
Auger	
Auger diameter	380 mm
Auger control	Proportional speed control. Left and right augers to be controlled separately. Reversible direction of rotation.
Engine	
Manufacturer	Deutz
Model	TCD2013L06V
Rated power	140 kW
Rated power	188 hp

Find your local dealer at www.dynapac.com

We reserve the right to change specifications without notice. Photos and illustrations do not always show standard versions of machines. The above information is a general description only, all informations are supplied without liability.

Rated power @
Electrical system
Emissions according to

1,800 rpm
24V
EU 3A / Tier 3

Find your local dealer at www.dynapac.com

We reserve the right to change specifications without notice. Photos and illustrations do not always show standard versions of machines.
The above information is a general description only, all informations are supplied without liability.

f141_4w_d_pavers_en-20090703.124254.pdf 2009-07-03 12:42