

MAX. OPERATING WEIGHT: 28.78 tonnes (63445lb) MAX. HORSEPOWER: 132 kW (177hp)

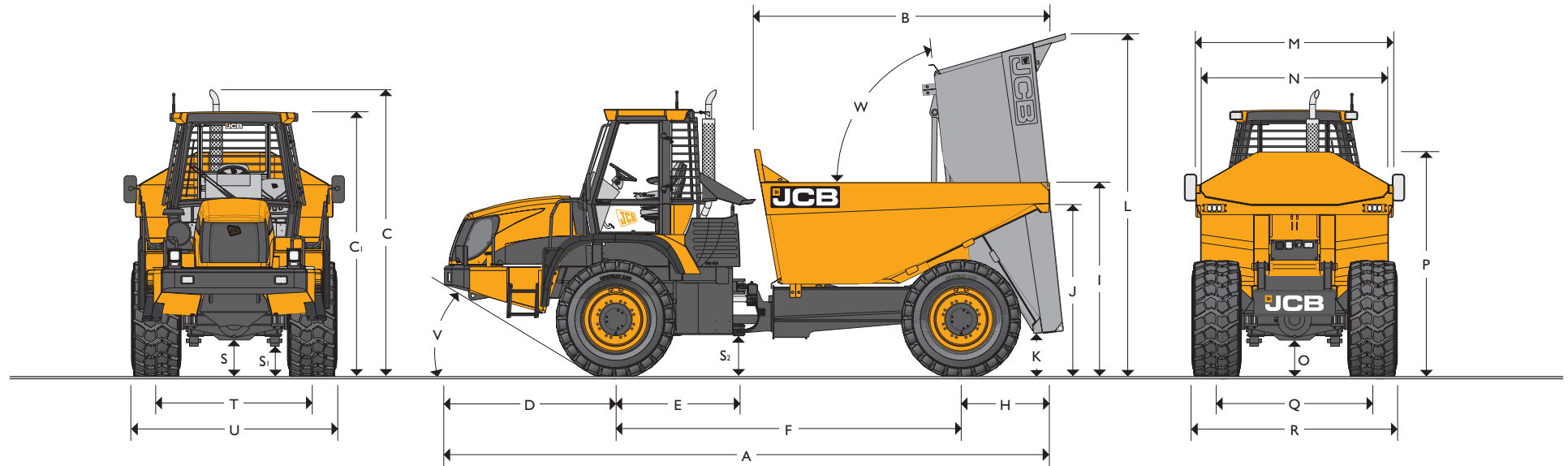

STATIC DIMENSIONS

	mm (ft-in)		mm (ft-in)
A Overall length	7709 (25-4)	O Max. ground clearance (rear diff)	430 (1-4)
B Body length	3745 (12-3)	P Max. body height to spill guard	2802 (9-2)
C Max. height	3575 (11-8)	Q Wheel track (rear)	1948 (6-4)
Ci Height to top of cab	3330 (10-11)	R Overall width (rear)	2608 (8-6)
D Front axle to front bumper	2174 (7-1)	S Max. ground clearance (front diff)	430 (1-4)
E Front axle to rear of front unit	1576 (5-2)	S1 Max. ground clearance (front suspension arm)	312 (1-0)
F Wheelbase (front axle to rear axle)	4400 (14-5)	S2 Ground clearance	438 (1-5)
H Rear axle to of body	1130 (3-7)	T Wheel track (front)	1948 (6-4)
I Height to top of body	2392 (7-10)	U Overall width	2608 (8-6)
J Height to lip of body	2141 (7-0)	V Departure angle (front)	degrees 30
K Min. height to body when tipped	473 (1-7)	W Body tip angle	degrees 84
L Max. height to body when tipped	4268 (14-0)	Load capacity	tonnes/lb 16.33 (36000)
M Max. external body width	2542 (8-4)	Body – heaped	m ³ (yd ³) 9.6 (12.56)
N Max. internal body width	2370 (7-8)		

Overall dimensions based on an unladen machine equipped with Michelin 650/65 R25 XAD tyres.

ENGINE

Type	6 cylinder direct injection diesel	
Model	QSB 6.7	
Capacity	litres (in ³)	6.7 (409)
Bore	mm (in)	107 (4.25)
Stroke	mm (in)	124 (4.75)
Aspiration	Turbocharged/charge cooled	
Cylinders	6	
Power rating		
Max. power	kW (HP) @ 2000 rpm	133 (178)
Gross power to SAE J1995/ISO 14396	kW (HP) @ 2200 rpm	129 (173)
Net power to SAE J1349/EEC80/1269	kW (HP) @ 2200 rpm	125 (168)
Torque rating		
Max. torque	Nm (lbf ft) @ 1400 rpm	800 (590)
Net torque	Nm (lbf ft) @ 1400 rpm	761 (561)

TRANSMISSION

Transmission	Type	Smoothshift
	Make	ZF
	Model	6WG160
Torque converter	Type	Single stage
	Torque converter ratio	1.792:1

AXLES

Type	Epicyclic hub reduction
Make	Graziano
Model	PR15
Overall axle ratio	23.538:1

SUSPENSION

Type (front)	4-bar parallel link
Make	JCB
Type (rear)	Fixed
Make	n/a

TRAVEL SPEEDS

Assumes fitment of Michelin 650/65 R25 tyres		kph (mph)
Forward	First	4.8 (3.0)
	Second	7.4 (4.6)
	Third	11.3 (7.0)
	Fourth	17.3 (10.7)
	Fifth	25.8 (16.0)
	Sixth	39.4 (24.5)
Reverse	First	5.0 (3.1)
	Second	11.9 (7.4)
	Third	27.2 (16.9)

HYDRAULICS

Steering and tipping	Pump type	Gear	
	Pump: max flow @ 2200rpm	l/min (UK gal/min)	121 (26.6)
	Pump: max pressure (MRV)	bar (psi)	207 (3000)
Braking	Pump type	Gear	
	Pump: max flow @ 2200rpm	l/min (UK gal/min)	17.6 (3.9)
	Pump: max pressure	bar (psi)	175 (2500)

SERVICE FILL CAPACITIES

	litres (UK gal)
Hydraulic system	160 (35)
Fuel tank	211 (46)
Engine oil sump	16.3 (3.58)
Transmission system	35 (7.7)
Axle oil (front)	29 (6.38)
Axle oil (rear)	29 (6.38)
Engine coolant system	30 (6.60)

ELECTRICAL SYSTEM

System voltage	Volt	24
Alternator output	Amp hour	70
Battery capacity	Amp hour	2 x 110

BODY

Tipping angle	degrees	84
Body plate thickness (front)	mm (ft-in)	6 (0-020)
Body plate thickness (side)	mm (ft-in)	6 (0-020)
Body plate thickness (bottom/chute)	mm (ft-in)	6 (0-026)
Yield strength	N/mm ² (psi)	1000 (145000)
Tensile strength	N/mm ² (psi)	1245 (181000)
Hardness (min)	HB	400
Body raise (laden)	seconds	12
Body lower (laden)	seconds	8
Scow angle	degrees	25

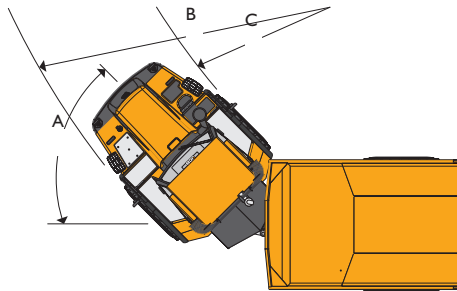
TURNING CIRCLE

		mm (ft-in)
A Articulation angle	degrees	40
B Clearance radius		7520 (24-7)
C Turning radius		4440 (14-6)

OPERATING WEIGHTS

		Unladen	Laden
Front Axle	tonnes (lb)	8.2 (18078)	11.85 (26131)
Rear Axle	tonnes (lb)	4.76 (10494)	17.45 (38473)
Total	tonnes (lb)	12.96 (28572)	29.3 (64604)

Includes operator (80kg) and a full fuel tank.

CHANGES TO GROUND BEARING PRESSURES

Manufacturer	Tyre Size	Type	Unladen		Laden		Tyre Pressure	
			Front	Rear	Front	Rear	Front	Rear
			kPa (PSI)	kPa (PSI)	kPa (PSI)	kPa (PSI)	kPa (PSI)	kPa (PSI)
Michelin	650/65 R25	XADN	86 (13)	50 (7)	125 (18)	184 (27)	248 (36)	400 (58)
Goodyear	650/65 R25	GP-3D	82 (12)	47 (7)	118 (17)	174 (25)	220 (32)	370 (54)
Nokian	750/55 R25	TRSL5-2	73 (11)	42 (6)	105 (15)	155 (23)	224 (32.5)	448 (65)
Trelleborg	850/45 B30.5	423TL	62 (9)	36 (5)	90 (13)	133 (19)	200 (29)	345 (50)

Ground bearing pressure @ 15% sinkage.

CHANGES TO OPERATING DIMENSIONS

Manufacturer	Tyre Size	Type	Dimensional changes				Operating weight
			U	T	R	Q	
			mm (in)	mm (in)	mm (in)	mm (in)	kg (lb)
Michelin	650/65 R25	XAD	0	0	0	0	0
Nokian	750/55 26.5	TRS LS-2	+180 (7.0)	+90 (3.5)	+180 (7.0)	+90 (3.5)	-772 (1698)
Trelleborg	850/45 B30.5	423TL	+380 (14.5)	+190 (7.5)	+380 (14.9)	+190 (7.5)	-980 (2156)
Goodyear	650/65 R25	GP-3D	+16 (0.6)	+8 (0.3)	+16 (0.6)	+8 (0.3)	-8 (1.8)

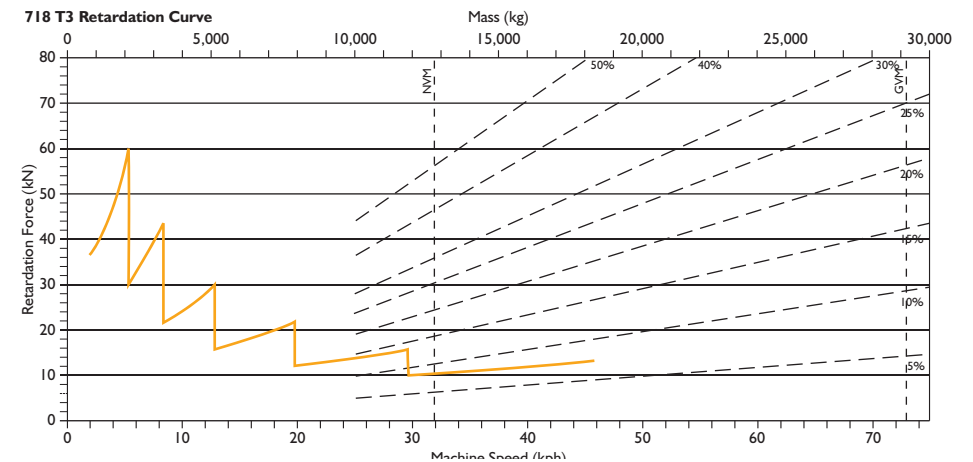
RETARDATION CURVE

STANDARD EQUIPMENT

Engine: 6 cylinder, direct injection diesel engine. Wastegate turbocharger charged cooler for maximum torque and minimum exhaust smoke. 3 stage dry type-cyclonic air cleaner with primary and safety elements. Stainless steel exhaust system, .

Suspension: Front suspension is a four bar parallel link mechanism connected via a gas strut to a pre charged accumulator that dampens the vibration. The system is self-levelling whether laden or un-laden.

Transmission: 6 forward and 3 reverse speed remote mount smoothshift transmission with integral lock up torque converter. Manual or automatic selection. Electrical 2/4 wheel drive selection.

Axles: Pad mounted to the front suspension and the rear chassis. Limited Slip Differential in both axles. Planetary wheel hub reduction.

Steering: Double acting hydrostatic system. Priority steer valve. Emergency steering via a ground driven pump.

Brakes: Dual circuit, hydraulic power dry disc type with braking on all four wheels. Electrically operated dry disc parking brakes on the driveline, spring applied and hydraulically released. Brake disc guards.

Hydraulics: Twin gear pump system comprising main pump for priority steer and body tip, and a second pump for braking. Emergency steer via a ground driven pump.

Cab: ROPS and FOPS safety structure. Fully adjustable air suspension seat. Adjustable steering column. Air conditioning. Laminated safety glass. Electronic monitoring panel with LCD message display which includes body up warning light. Front & rear screen wash / wipe. 3 speed heater / demisting with replaceable air filter. LH & RH opening doors. Single lever transmission selector. Single lever hydraulic tip control. Combination stalk controls for lights, wipers, horn, direction indicators. Separate side consul for auxiliary switches. Interior light, sun visor, external rear view mirrors, and operator's storage facilities.

Electrical: Road lights front and rear, front working lights, reversing alarm and light, rear fog lights, horn, battery isolator, beacon, radio fittings, 70 amp alternator.

Bodywork: Flexible front steps, non-slip walkways, recovery hitch, lifting lugs (rear body), engine access cover. Rear cab mounted spill guard. Cast 360 deg centre hitch.

Body: Constructed from high strength steel with large box section stiffeners. Large target area and load retention. Two single stage double acting cylinders located within rear chassis.

OPTIONAL EQUIPMENT

Reversing camera; Biodegradable hydraulic oil; Smart reverse alarm; 3" seat belt; Mechanical tail gate; Fire extinguisher; 24-12 volt in cab converter; Air suspension seat with lumbar support; Body front extension plate; Number plate kit; LiveLink telematics.

