

**NEW**

VMT380 / VMT430 | **TANDEM ROLLERS**



## VMT380 and VMT430 Tandem Rollers

Operating Weight: 3750kg – 4300kg Drum Width: 1300mm – 1400mm





# QUALITY, RELIABILITY, DURABILITY

JCB TANDEM ROLLERS ARE BUILT TO WITHSTAND THE RIGOURS OF SURFACE-LAYING. USING STATE-OF-THE-ART DESIGN PROCESSES LIKE FINITE ELEMENT ANALYSIS, WE'VE BUILT SERIOUSLY TOUGH MACHINES THAT DELIVER MAXIMUM PERFORMANCE WITH LOW OPERATING COSTS.

## Made to last

- 1 JCB VMT 380 and 430 rollers use a single piece exciter shaft, machined from one solid piece of steel. There's nothing to fail or work loose.
- 2 All the drum hoses are routed inside the drum supports to keep them out of harm's way.
- 3 With high lifting points, slings and chains won't damage the upper structure during craning.
- 4 We've made the centre joint using cast iron sections and finite element analysis to guarantee durability.
- 5 The VMT 380 and 430 machines' IP69 electrics are fully sealed to withstand pressure washing or rain.
- 6 The cooling system is rear-mounted inside the metal structure for optimum protection.
- 6 All upper structures are narrower than the drum ends to prevent damage while manoeuvring.

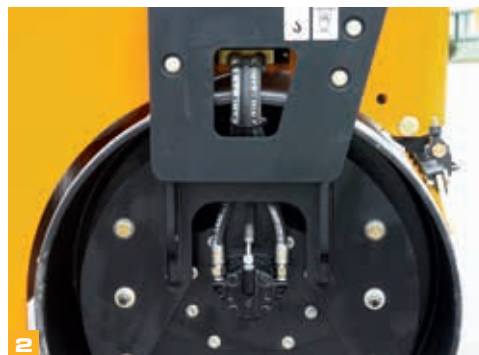
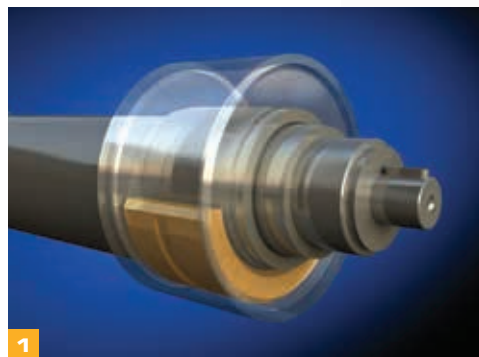

A stiff front bonnet recessed and protected by a steel bull bar gives maximum impact protection.



### Roll on productivity

- 7** Our automatic vibration control activates whenever the drive lever is moved from the neutral position, providing the perfect finish at layer ends.
  - 8** With three frequency settings (50/59/66 Hz), you can tailor your VMT machine to your exact requirements. The high speed, high frequency setting of 66 Hz allows you to get the job done quickly and is excellent for fast stiffening materials.
  - 9** Our class-leading 63 kN vibrator performance makes for superb productivity.
  - 10** The VMT 380 and 430 machines are highly versatile; there are double, single-front and single-rear vibration settings.
  - 11** A tight turning circle makes for excellent manoeuvrability on confined sites.
- To get your machine around obstacles, we've built in up to 80 mm drum offset.
- 12** Gradeability of the VMT 380 and 430 machines is a class-leading 42% for great versatility. We've achieved this via a high performing 4 cylinder diesel engine, high torque hydraulic components and optimised weight distribution.





## SERVICEABILITY, SAFETY, SECURITY

TO GET THE BEST POSSIBLE RETURN ON YOUR INVESTMENT, YOU NEED TO MINIMISE DOWNTIME. TO DO THAT, YOU NEED MAXIMUM SERVICEABILITY, SAFETY AND SECURITY. FORTUNATELY, OUR VMT 380 AND 430 MACHINES ARE DESIGNED TO EXCEL IN ALL THESE AREAS.



1

### Roll on serviceability

VMT 380s and 430s are grease-free machines. All bearings are Teflon-coated and the centre joint is sealed for grease-free zero-maintenance use. Exciter shaft vibration bearings are maintenance-free.

- 1 The 4 drum scrapers are spring loaded and easy to remove. An additional lock means you can position the scraper off the drum avoiding unnecessary wear of scrapers.
- 2 We've designed unique 3-point preloaded rubber mountings, meaning that mounts can't be overloaded.
- 3 Daily checks are easy and access is superb via a wide opening front bonnet. The radiator is easy to clean and you can access the battery without tools.



2



3

### Roll on safety and security

4 Reduced noise and class-leading low vibration levels allow fatigue-free all-day operation. Our low vibration levels are achieved partly by mechanically isolating the drivers seat, steering column, lever and footplate.

The optional flip over vandal cover protects the dashboard and controls from damage and unauthorised access.

5 We've built wide non-slip access steps on both sides of these machines.

6 A reflective paint and decal option makes a VMT 380 or 430 clearly visible in all light conditions.

### Robust water spray system

7 A large 210 litre water tank provides maximum uptime between refills, while a large water filler cap makes for quick and easy filling, together with easy identification of the water tank. Draining the water tank is easy and, because the plug is at the lowest point, the tank can be completely emptied.

8 Our triple filter water system means trouble-free efficient water supply for maximum uptime. There's a prefilter in the water tank, an inline filter and an easy clean nozzle filter.

9 The VMT 380 and 430 machines use easy-access solid metal spray bars with drain valves and changeable anti-frost nozzles.





# COMFORT, VISIBILITY, CUSTOMER SUPPORT

AT JCB, WE DESIGN OUR MACHINES AROUND THE OPERATOR. AFTER ALL, A COMFORTABLE OPERATOR IS AN ALERT, PRODUCTIVE OPERATOR. WITH THIS IN MIND, OUR OPERATOR PLATFORM IS DESIGNED TO BE ERGONOMIC, WITH GOOD VISIBILITY. AND WITH YOUR BUSINESS IN MIND, WE DELIVER WORLD-BEATING CUSTOMER CARE.

## Comfortably better, visibly better

**1** We've equipped the VMT 380 and 430 with a tapered front frame and low bonnet profile, providing excellent visibility to the front drum edges.

**2** The operator's seat can be laterally repositioned for improved versatility, comfort and visibility.

A low rear water tank and low profile rear frame means excellent rear visibility.

## Customer support

**3** Benefit from fast, efficient customer care that's dedicated to making sure your machinery performs to its full potential.

Our Technical Support Service provides instant access to factory expertise, day or night.

JCB's Finance and Insurance teams can provide fast, flexible, competitive quotes, as well as Assetcare extended warranties and service agreements.

Our maintenance teams charge competitive labour rates.

**4** The global network of JCB Parts Centres delivers 95% of parts anywhere in the world within 24 hours.

Controls are intuitive, easy to use and laid out to the industry standard for quick acclimatisation and maximum productivity.



**STATIC DIMENSIONS**

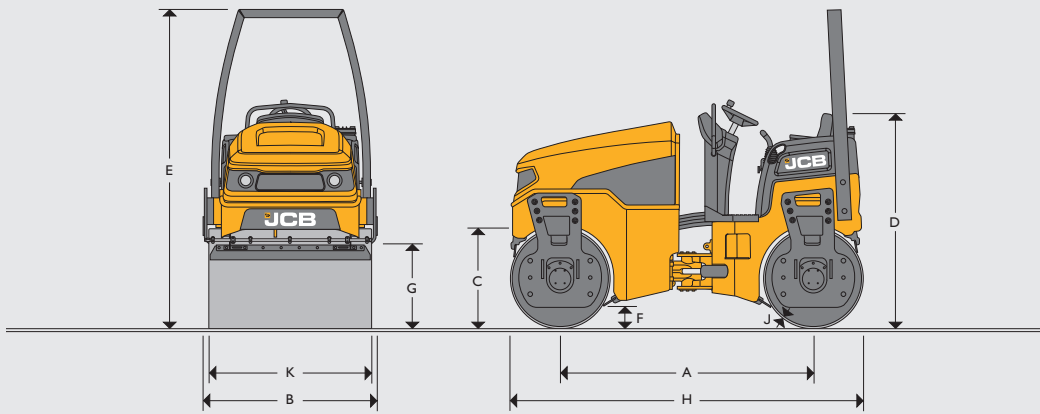

Dimensions in millimetres	VMT380-130	VMT380-140	VMT430-130	VMT430-140
A Wheelbase	2020	2020	2020	2020
B Overall width	1390	1490	1390	1490
C Drum diameter	800	800	800	800
D Height to top of seat	1720	1720	1720	1720
E Height to top of ROPS	2550	2550	2550	2550
F Ground clearance	300	300	300	300
G Curb clearance	680	680	680	680
H Total travel length	2820	2820	2820	2820
J Drum thickness	17	17	17	17
K Drum width	1300	1400	1300	1400

**OPERATION DATA**

		VMT380-130	VMT380-140	VMT430-130	VMT430-140
Operating weight (CECE)	kg	3750	3850	4200	4300
Maximum operating weight*	kg	4100	4200	4550	4650
Operating linear load	kg/cm	14.4	13.8	16.2	15.4
Exciter frequency	Hz	50 / 59 / 66	50 / 59 / 66	50 / 59 / 66	50 / 59 / 66
Nominal amplitude	mm	0.44	0.44	0.44	0.44
Centrifugal force (each drum)	kN	59	63	59	63
Working speed range	km/h	0 - 9	0 - 9	0 - 9	0 - 9
Drum offset right	mm	80	80	80	80
Steering lock angle	°	± 36	± 36	± 36	± 36
Oscillation angle	°	± 13	± 13	± 13	± 13
Inner turning radius	mm	2490	2440	2490	2440
Max. gradeability without vibration (dependant on site conditions)	° (%)	22.8 (42)	22.8 (42)	22.8 (42)	22.8 (42)

**ENGINE**

Make	Kohler		
Model	KDW 2204 (TIER4i)		
Type	4 -Stroke Diesel, liquid cooled		
Piston displacement	cm <sup>3</sup>	2199	
Performance	kW (hp)	33.6 (45.7)	
Operating speed	min-1 (rpm)	2700	
Starting device	Electric motor		
Air cleaner	Dry cartridge plus safety cartridge		
Fuel filter	Cartridge		

**PROPULSION**

Hydrostatic with variable displacement pump and fixed displacement motors with direct drive to both drums = double drum drive.

**EXCITER DRIVE**

Electrically controlled hydrostatic direct drive on both drums for double vibration or single vibration front or rear.

**EXCITER**

Single-piece circular exciter shaft with one amplitude and three frequencies.

**STEERING SYSTEM**

Servo assisted, maintenance free articulation with oscillation facility.

**SERVICE CAPACITIES**

Fuel	litres	100
Sprinkler water	litres	210

**BRAKING SYSTEM**

Service brake	Hydrostatic drive	
Parking brake	SAHR	

**ELECTRICAL SYSTEM**

Working lights, backup alarm, safety switch in operators seat.		
Voltage	V	12
Battery capacity	Ah	74
Alternator	A	80

**DRIVERS STAND/INSTRUMENTS**

Fully isolated operator stand, sliding operator seat, ergonomic drive lever with integrated auxiliary hydraulic functions, storage for manuals and tools, tea cup holder, detented throttle with four positions, fuse box easily accessible on side of steering column, access and egress to driver stand from both sides with large steps and ergonomic handrails.

**OPTIONS**

ROPS frame or folding ROPS (standard in CE regions), sun roof for ROPS, road light kit + grid protection, edge cutting and pressing device, chip spreader, flow divider, beacon including under-bonnet storage, water sprinkler off in neutral, additional worklights, drum edge lighting, reflective strips on steps, reverse alarm, 2nd drive lever, instrument panel cover, brass nozzles and bar, quick release nozzles, german road homologation, tool kit, bio-degradable hydraulic oil, tropical hydraulic oil, fan guard.



### **VMT380 and VMT 430 Tandem Rollers**

Operating Weight: 3750kg – 4300kg

Drum Width: 1300mm – 1400mm

Your nearest JCB dealer

JCB Sales Limited, Rocester, Staffordshire, United Kingdom ST14 5JP. Tel: +44 (0)1889 590312 Email: [salesinfo@jcb.com](mailto:salesinfo@jcb.com) Download the very latest information on this product range at: [www.jcb.com](http://www.jcb.com)

©2009 JCB Sales. All rights reserved. No part of this publication may be reproduced, stored in a retrieval system, or transmitted in any form or by any other means, electronic, mechanical, photocopying or otherwise, without prior permission from JCB Sales. All references in this publication to operating weights, sizes, capacities and other performance measurements are provided for guidance only and may vary dependant upon the exact specification of machine. They should not therefore be relied upon in relation to suitability for a particular application. Guidance and advice should always be sought from your JCB Dealer. JCB reserves the right to change specifications without notice. Illustrations and specifications shown may include optional equipment and accessories. The JCB logo is a registered trademark of J.C. Bamford Excavators Ltd.