

Crawler excavator

R 906
Litronic®

Advanced/Classic

Operating Weight: 22,350 – 25,250 kg
Engine Output: 105 kW / 143 hp
Bucket Capacity: 0.80 – 1.35 m³



Fig. R 906 Advanced

LIEBHERR

Advanced/Classic

R 906 Litronic®

Operating Weight: 22,350 – 25,250 kg
Engine Output: 105 kW / 143 hp
Bucket Capacity: 0.80 – 1.35 m³



Performance

Thanks to its innovative Advanced excavator system technology, the R 906 Advanced crawler excavator has performance features that are truly unique. Characteristic elements of this system technology include the particularly effective and energy-efficient Positive Control twin-circuit hydraulic system, which was specifically designed for machines with a high level of superimposed functions and operational movements. The electronic pump control arrangement sets this technology apart, creating a new standard for performance and quantity control that entirely matches the operator's needs.

Reliability

Liebherr provides customers with solutions that lead the way for the future, solutions for maximum equipment reliability and availability, solutions which satisfy the most extreme demands for performance and quality. With more than 50 years experience in the construction of hydraulic excavators, we have an advantage in design and consultation that clearly sets us apart.

Comfort

In the cab the driver can look forward to a workplace designed in accordance with the very latest findings in ergonomic science, with emphasis on comfort and ease of operation. The optimised arrangement of the hydraulic hoses means that the driver has an even wider field of vision, and the heating and climate control system fitted as standard means pleasant working conditions inside, whatever the weather. Liebherr crawler excavators are also particularly easy to service – maintenance tasks can be carried out easily and rapidly at readily accessible service points.

Economy

Crawler excavators from Liebherr guarantee maximum productivity. The optimum interplay of hydraulics and electronics means that individual movements and superimposed movements alike can be carried out particularly efficiently. And, perhaps last but by no means least, the perfect harmonisation of all the components means that energy expenditure during operation can be kept to an absolute minimum.



Fig. R 906 Advanced (ahead)
R 906 Classic (background)



Advanced / Classic



Fig. R 906 Classic

Positive Control twin-circuit hydraulic system

- Fast and precise provision of the volume flow needed, even with superimposed movements
- Load-sensitive control for harmonious operating movements
- Optimum energy utilisation

Advanced



Fig. R 906 Advanced

Performance

Thanks to its innovative Advanced excavator system technology, the R 906 Advanced crawler excavator has performance features that are truly unique. Characteristic elements of this system technology include the particularly effective and energy-efficient Positive Control twin-circuit hydraulic system, which was specifically designed for machines with a high level of superimposed functions and operational movements. The electronic pump control arrangement sets this technology apart, creating a new standard for performance and quantity control that entirely matches the operator's needs.

Advanced integrated excavator system technology

High-tech for high performance

Among the high-tech equipment on the Advanced version of the R 906 is the newly-developed integrated excavator system technology. This is based on the Positive Control hydraulic system, controlled by Liebherr electronics and the system software. The sensors located at strategic points on the machine form the basis for an intelligent system that allows for fast and fluent working.

Positive Control twin-circuit hydraulic system

When travelling straight or in a curve, and during levelling work, the two pump circuits of the hydraulic system are separated or grouped together, as the need arises. Separation of the systems means that different consuming components can be supplied with different load pressures independently, and saving energy too. By contrast, grouping the pump circuits allows for maximum speeds with individual or superimposed movements, and that means optimum energy utilisation.

Power and speed

Faster work cycles

The R 906 achieves particularly fast work cycles, thanks, for example, to the powerful slewing drive of the superstructure, the rapid slewing rates, and the creation of high slewing torque.

Advanced operating pressure

With an operating pressure of 365 bar, the R 906 Advanced achieves higher hydraulically limited load capacities and higher digging forces, of up to 134 kN, and break-out forces of up to 158 kN; perfect for more difficult operational situations such as canal or pipeline construction.

Classic operating pressure

An operating pressure of 350 bar makes the R 906 Classic fully equipped to tackle all earth moving work.



Fig. R 906 Advanced

Wide range of operational possibilities

- Large number of equipment variants
- Versatile selection of undercarriage variants
- Broad operational spectrum, from earthmoving, to grading work, to demolition



Powerful Liebherr engines

- Four-cylinder diesel engines developed and manufactured by Liebherr specifically for construction machines, with system integration by means of CANBus and pump line nozzle injection system
- Efficient power output, high degree of efficiency, and long service life
- High performance output from the unit already in the low revolution range makes a major contribution to the economical operation of the entire excavator

Advanced

Advanced / Classic

Advanced

Classic



Advanced / Classic



Safe reliable transport

- Lashing eyes integrated into the undercarriage as standard make transport of the excavator both safe and reliable
- The lashing eyes are compatible with all conventional securing means and materials available on the market

Advanced / Classic



Reliability

Liebherr provides customers with solutions that lead the way for the future, solutions for maximum equipment reliability and availability, solutions which satisfy the most extreme demands for performance and quality. With more than 50 years experience in the construction of hydraulic excavators, we have an advantage in design and consultation that clearly sets us apart.

High stability undercarriage

Better force distribution The new undercarriage concept of the generation 6 crawler excavators leads to increased performance with improved service life. Thanks to the connection of the middle section being extended as far as the ends of the chassis beams, known as the X-design, the forces are better distributed, which increases the service life of the undercarriage.

High performance travel drive

Thanks to its powerful travel drive, the R 906 is particularly well-suited for the transport of large loads across difficult terrain. The larger sprocket wheel reduces track vibrations and increases travel speed to 6.1 km/h, making the R 906 the fastest excavator in this class.

Technology with perspective

Quality right down to the last detail

The at-a-glance layout of the hydraulic, lubrication, and electricity lines makes for optimum functional reliability and maximum availability of the unit. Best possible corrosion protection is guaranteed thanks to components and modules being final-painted and surface treated before assembly.

ROPS cab structure

The cab is equipped with an integrated roll-over protection system (ROPS) in accordance with ISO 12117-2, guaranteeing driver safety in any situation.

Ready for the demands of the future

The Advanced Liebherr system technology can be updated at any time by Liebherr Service personnel to a newer version, which makes it ready to meet the demands of the future and prepared for the further development of the electronic options.



Fig. R 906 Classic

Key technologies – Made by Liebherr

- Perfect matching of the components to construction machine operations
- Engine, hydraulic pumps, transfer gears, travel drives, slewing drives, slewing rings, and electronic components – all from the same source
- Main steel components, such as undercarriage, equipment modules, and slewing superstructure, all designed by Liebherr



Spare parts service

- Any spare parts required are available within 24 hours – worldwide. And that means high operational readiness of the machines, wherever, whenever
- Over 80,000 spare parts in stock at all times



Classic



Classic cab

- Best possible view thanks to large-scale windows
- Driver's seat can be individually adjusted and is vibration-damped
- Automatic heating/climate control as standard
- Right-hand pane without middle bar
- Closed stowage space
- Front, roof, and side window panes made of laminated safety glass
- Integrated roll-over protection system (ROPS)

Advanced



Comfort

In the cab the driver can look forward to a workplace designed in accordance with the very latest findings in ergonomic science, with the emphasis on comfort and ease of operation. The optimised arrangement of the hydraulic hoses means that the driver has an even wider field of vision, and the heating and climate control system fitted as standard means pleasant working conditions inside, whatever the weather. Liebherr crawler excavators are also particularly easy to service – maintenance tasks can be carried out easily and rapidly at readily accessible service points.

Safe work – with a clear layout

A pleasant workplace

The entirely new design of the Advanced cab provides plenty of room, and creates a pleasant sense of space. Cab windows in the front, the roof, and on the right are made of break-resistant two-pane safety glass. The front windscreen is a two-part design and can be completely retracted. The cab meets ROPS requirements, providing the driver with even more protection.

High-resolution colour display

The 7-inch high-resolution colour display can be operated optionally as a touch-screen system or rotating/pushbutton arrangement. Thanks to its high resolution, the video-style display reproduces the image from the rear area monitoring camera in the best possible quality. It comes with versatile adjustment, control, and monitoring capabilities, and is designed to be glare-free.

Wide camera viewing field

The optional rearview camera for the R 906 Advanced, with a viewing angle of more than 120°, provides a complete view of the area behind the machine.

Fully automatic climate control system

The climate control system has more than 12 adjustable nozzles for individual control of air flow, and can be operated via the display. For heating operation, the fuel-saving Econ mode is available, in which the climate control compressor is switched off.

Minimal noise and vibration

The new cab on the Liebherr crawler excavator meets the standards for noise emissions and whole-body vibrations, which makes work a pleasure.



Fig. R 906 Advanced

Advanced cab

In addition to the equipment features of the Classic cab:

- Newly developed driver's position as standard
- Air-suspension seat with automatic weight adjustment and horizontal suspension for maximum comfort – as standard
- For optimum ease of operation and fatigue-free working, the operating consoles pivot with the seat



Extremely maintenance-friendly

- All maintenance points are easily accessible
- Daily routine servicing work can be carried out very rapidly, reliably, and in comfort
- The Advanced version comes as standard with a fully-automatic central lubrication system, and the Classic with a semi-automatic arrangement



Advanced / Classic



Liebherr Tool Control

- Memory storage of up to ten tool settings (pressure and oil flow)
- Display of the designation of the add-on attachments and tools
- If the hydraulic attachment is changed, once the new tool has been chosen the system presents the programmed pressure values and oil flow volumes in the menu

Advanced / Classic



Economical

Crawler excavators from Liebherr guarantee maximum productivity. The optimum interplay of hydraulics and electronics means that individual movements and super-imposed movements alike can be carried out particularly efficiently. And, perhaps last but by no means least, the perfect harmonisation of all the components means that energy expenditure during operation can be kept to an absolute minimum.

Economical technology

Costs savings thanks to fuel efficiency

Classic

Tests have shown that the new crawler excavators from Liebherr use even less fuel than the units of the previous generation. The electronic engine speed sensing control creates efficient conversion of engine output into hydraulic performance. The result: Faster and more powerful working while cutting fuel consumption at the same time; which means less stress for the diesel engine, too.

Advanced

The Advanced crawler excavator is even more economical when it comes to fuel consumption. Fuel savings are achieved thanks to the integrated excavator system technology and the efficient engine and hydraulics management. When at rest, the sensor-controlled function automatically brings the engine revolution speed down to idling, which reduces fuel consumption and emission values, and helps save the environment - as well as costs.

Value retention

High resale value

Liebherr excavators are built to last, with top quality materials given top quality workmanship – and that guarantees top value retention.

Environmental protection and recycling

All Liebherr engines meet the exhaust gas directives specified by law, of Stage IIIA/ Tier 3, which means reduced nitrogen oxide and fine dust emissions. This effect is supported even further by the optionally available Liebherr particle filter. With Liebherr, concern for the environment is extended to the whole machine. Up to 95 % of all the components from a Liebherr excavator can be recycled, and only lead-free paints are used.



Fig. R 906 Advanced

Innovative tooth system

- Patented tooth system, consisting of tooth holder, tooth, securing bolts, and protective plugs
- Teeth can be replaced rapidly and without the use of force
- Tooth shapes for every operational situation

Advanced / Classic



Modular particle filter (optional)

- Reduction in fine dust emissions
- Consists of intake, filter, outlet, and muffler modules
- Certified in accordance with the VERT filter list

Classic

Advanced

Advanced / Classic



Engine

Rating per ISO 9249	105 kW (143 HP) at 1,800 RPM
Model	Liebherr D 934 S
Type	4 cylinder in-line
Bore/Stroke	122/136 mm
Displacement	6.36 l
Engine operation	4-stroke diesel unit pump system turbo-charged after-cooled and fuel cooled reduced emissions
Cooling	water-cooled and integrated motor oil cooler
Air cleaner	dry-type air cleaner with pre-cleaner, primary and safety elements
Fuel tank	380 l
Electrical system	
Voltage	24 V
Batteries	2 x 135 Ah/12 V
Starter	24 V/6.6 kW
Alternator	three phase current 28 V/80 A
Engine idling	sensor-controlled
Integrated motor management	
Advanced	connection to the integrated excavator system controlling via CAN-BUS to the economical utilisation of the service that is available



Hydraulic System

Hydraulic system	Positive Control Advanced. Dual circuit hydraulic system for independent and need-based quantity allotment via the hydraulic pumps; sensor-guided. Features high system dynamics and sensibility provided by integrated system controlling
Hydraulic pump	Liebherr variable displacement pump built in transversal plate style, in parallel arrangement with integrated transfer box
Max. flow	2 x 214 l/min.
Max. pressure	365 bar
Pump management	electronic pump management via the integrated system controlling (CAN-BUS) synchronous to the control block
Hydraulic tank	290 l
Hydraulic system	max. 500 l
Hydraulic oil filter	1 full flow filter (20 µm) in return line with integrated fine filter area (5 µm)
Hydraulic oil cooler	compact cooler, consisting of a water cooler, sandwiched with hydraulic oil cooler, fuel cooler and after-cooler cores and hydrostatically driven fan
MODE selection	adjustment of engine and hydraulic performance via a mode pre-selector to match application, e.g. for especially economical and environmentally friendly operation or for maximum digging performance and heavy-duty jobs
RPM adjustment	stepless adjustment of engine output via RPM at each selected mode
Liebherr Tool-Control	10 preadjustable pump flows and pressures for add-on tools



Hydraulic Controls

The controlling is conducted via the integrated excavator system technology, input and output modules, communicated via the CAN-BUS with the electronic central unit.

Power distribution	via control valve with integrated safety valves
Servo circuit	
Attachment and swing	proportional via joystick levers
Travel	– with proportionally functioning foot pedals or adjusted with a plugable lever – speed pre-selection
Additional functions	proportional regulation via slide switches or foot pedals



Swing Drive

Advanced	shockless and antireaction
Drive by	Liebherr swash plate motor
Transmission	Liebherr compact planetary reduction gear
Swing ring	Liebherr, sealed single race ball bearing swing ring, internal teeth
Swing speed	0 – 11 RPM stepless
Swing torque	71.1 kNm
Holding brake	wet multi-disc (spring applied, pressure released)



Operator's Cab

Cab	ROPS safety cab structure (capable of sweeping over) with individual windscreens or featuring a slide-in subpart under the ceiling, work headlights integrated in the ceiling, a door with a side window (can be opened on both sides), large stowing and depositing possibilities, shock-absorbing suspension, sounddamping insulating, tinted laminated safety glass, separate window shades for the sunroof window and windscreen
Operator's seat	Liebherr-Air-Comfort seat, airsprung with automatic weight adjustment, vertical and horizontal seat damping including consoles and joysticks. Seat and armrests adjustable separately and in combination, seat heating as standard
Control system	arm consoles, swinging with the seat
Operation and displays	large high resolution colour display with self-explanatory operation via touch screen or turn-push button, video capability, versatile adjusting, control and monitoring facilities, e.g. climate control, implement and tool parameters
Air-conditioning	standard automatic air-conditioning, ambient air function, fast de-icing and demisting at the press of a button, air vents can be operated via a menu; ambient air and fresh air filters can be easily replaced and are accessible from the outside; heating-cooling unit, designed for extreme outside temperatures, sensors for solar radiation, inside and outside temperatures

Noise emission	
ISO 6396	L_{DA} (inside cab) = 71 dB(A)
2000/14/EC	L_{WA} (surround noise) = 101 dB(A)



Undercarriage

Versions	
NLC	gauge 2,000 mm with longer crawler length
LC	standard gauge 2,250 mm with longer crawler length
WLC	gauge 2,380 mm with longer crawler length
Drive	Liebherr swash plate motors with integrated brake valves on both sides
Transmission	Liebherr planetary reduction gears
Travel speed	low range – 3.7 km/h high range – 6.1 km/h
Net drawbar pull on crawler	190 kN
Track components	B 60, maintenance-free
Track rollers/Carrier rollers	8/2
Tracks	sealed and greased
Track pads	triple-grouser
Digging locks	wet multi-discs (spring applied, pressure released)
Brake valves	integrated into travel motor
Lashing eyes	integrated



Attachment

Type	combination of resistant steel plates and cast steels components
Hydraulic cylinders	Liebherr cylinders with special seal-system, shock absorbed
Pivots	sealed, low maintenance
Lubrication	automatic central lubrication system (except link and tilt geometry)
Hydraulic connections	pipes and hoses equipped with SAE splitflange connections
Bucket	fitted as standard with Liebherr tooth system



Engine

Rating per ISO 9249	105 kW (143 HP) at 1,800 RPM
Model	Liebherr D 934 S
Type	4 cylinder in-line
Bore/Stroke	122/136 mm
Displacement	6.36 l
Engine operation	4-stroke diesel unit pump system turbo-charged after-cooled and fuel cooled reduced emissions
Cooling	water-cooled and integrated motor oil cooler
Air cleaner	dry-type air cleaner with pre-cleaner, primary and safety elements
Fuel tank	380 l
Electrical system	
Voltage	24 V
Batteries	2 x 135 Ah/12 V
Starter	24 V/6.6 kW
Alternator	three phase current 28 V/80 A
Engine idling	sensor-controlled



Hydraulic System

Hydraulic system	Positive Control Classic. Dual circuit hydraulic system for independent and need-based quantity allotment via the hydraulic pumps
Hydraulic pump	Liebherr variable displacement pump built in transversal plate style, in parallel arrangement with integrated transfer box
Max. flow	2 x 214 l/min.
Max. pressure	350 bar
Pump regulation	electro-hydraulic with electronic engine speed sensing regulation, pressure compensation, flow compensation, automatic oil flow optimizer, swing circuit with priority and torque control. 2 independent circuits with hydraulic pump summation for individual equipment movements
Hydraulic tank	290 l
Hydraulic system	max. 500 l
Hydraulic oil filter	1 full flow filter (20 µm) in return line with integrated fine filter area (5 µm)
Hydraulic oil cooler	compact cooler, consisting of a water cooler, sandwiched with hydraulic oil cooler, fuel cooler and after-cooler cores and hydrostatically driven fan
MODE selection	adjustment of engine and hydraulic performance via amode pre-selector to match application, e.g. for especially economical and environmentally friendly operation or for maximum digging performance and heavy-duty jobs
RPM adjustment	stepless adjustment of engine output via RPM at each selected mode
Liebherr Tool-Control	10 preadjustable pump flows and pressures for add-on tools



Hydraulic Controls

The control of movements steered by joysticks demand are regulated by a hydraulic valve block.

Power distribution	via control valve with integrated safety valves
Servo circuit	
Attachment and swing	proportional via joystick levers
Travel	- with proportionally functioning foot pedals or adjusted with a plugable lever - speed pre-selection
Additional functions	via foot pedals or buttons



Swing Drive

Drive by	Liebherr swash plate motor
Transmission	Liebherr compact planetary reduction gear
Swing ring	Liebherr, sealed single race ball bearing swing ring, internal teeth
Swing speed	0 - 11 RPM stepless
Swing torque	71.1 kNm
Holding brake	wet multi-disc (spring applied, pressure released)



Operator's Cab

Cab	ROPS safety cab structure (capable of sweeping over), built from deep-drawn components, resiliently-mounted, sound-insulated, tinted windows, front window stores overhead, door with sliding window
Operator's seat	shock-absorbing suspension, adjustable to operator's weight, 6-way adjustable seat
Control system	integrated into the adjustable console panel in the operator's seat
Monitoring	menu driven query of current operating conditions via the display. Automatic monitoring, display, warning (acoustical and optical signal) and saving machine malfunction data, for example; engine overheating, low engine oil pressure or low hydraulic oil level
Air-conditioning	standard air conditioning, combined cooler/heater, additional dust filter in fresh air/recirculated
Noise emission	
ISO 6396	L _{PA} (inside cab) = 71 dB(A)
2000/14/EC	L _{WA} (surround noise) = 101 dB(A)



Undercarriage

Versions	
NLC	heavy duty, gauge 2,000 mm with longer crawler length
LC	heavy duty, standard gauge 2,250 mm with longer crawler length
WLC	gauge 2,380 mm with longer crawler length
Drive	Liebherr swash plate motors with integrated brake valves on both sides
Transmission	Liebherr planetary reduction gears
Travel speed	low range - 3.7 km/h high range - 6.1 km/h
Net drawbar pull on crawler	184 kN
Track components	B 60, maintenance-free
Track rollers/Carrier rollers	8/2
Tracks	sealed and greased
Track pads	triple-grouser
Digging locks	wet multi-discs (spring applied, pressure released)
Brake valves	integrated into travel motor
Lashing eyes	integrated



Attachment

Type	combination of resistant steel plates and forged components
Hydraulic cylinders	Liebherr cylinders with special seal-system, shock absorbed
Pivots	sealed, low maintenance
Lubrication	semi-automatic central lubrication system (except link and tilt geometry)
Hydraulic connections	pipes and hoses equipped with SAE splitflange connections
Bucket	fitted as standard with Liebherr tooth system

Dimensions

Advanced

Advanced

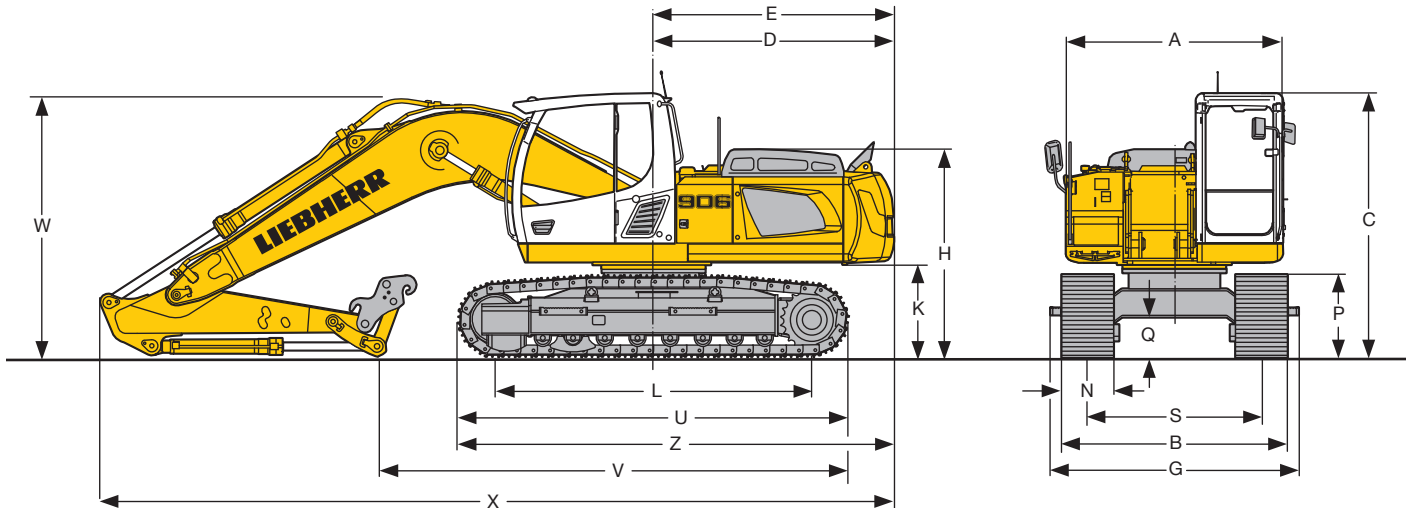

	NLC			LC			WLC		
	mm			mm			mm		
A	2,500			2,500			2,500		
C	3,047			3,047			3,047		
D	2,770			2,770			2,770		
D*	2,770			2,770			2,770		
E	2,790			2,790			2,790		
E*	2,940			2,940			2,940		
H	2,402			2,402			2,402		
K	1,095			1,095			1,095		
L	3,648			3,648			3,648		
P	955			955			955		
Q	460			460			460		
S	2,250			2,000			2,380		
U	4,510			4,510			4,510		
Z	5,030			5,030			5,030		
Z*	5,180			5,180			5,180		
N	500	600	750	500	600	750	500	600	750
B	2,500	2,600	2,750	2,750	2,850	3,000	2,880	2,980	3,130
G	2,480	2,780	2,780	2,810	2,810	3,110	2,940	2,940	3,240

Mono Boom 5.40 m					
Stick length	m	2.20	2.40	2.70	3.00
V	mm	5,450	5,200	4,950	4,700
W	mm	3,000	3,050	3,050	3,100
X	mm	9,200	9,200	9,200	9,200

Straight Mono Boom 5.70 m					
Stick length	m	2.20	2.40	2.70	3.00
V	mm	6,000	5,850	5,650	5,450
W	mm	2,800	2,850	2,900	3,050
X	mm	9,550	9,550	9,550	9,550

Two-piece Boom 3.50 m						
Stick length	m	2.20	2.40	2.70	3.00	
V	mm	6,000	5,900	5,600	5,400	
W	mm	2,700	2,750	2,800	2,850	
X	for NLC-Undercarriage	mm	9,850	9,850	9,850	9,900
	for LC-Undercarriage	mm	9,700	9,700	9,700	9,750
	for WLC-Undercarriage	mm	9,700	9,700	9,700	9,750

Offset Mono Boom 5.50 m					
Stick length	m	2.20	2.40	2.70	3.00
V	mm	5,550	5,400	5,150	4,900
W	mm	2,700	2,750	2,800	2,850
X	mm	9,450	9,450	9,450	9,500

* with heavy counterweight
 E = Tail radius
 G = Width with removable steps

Dimensions

Classic

Classic

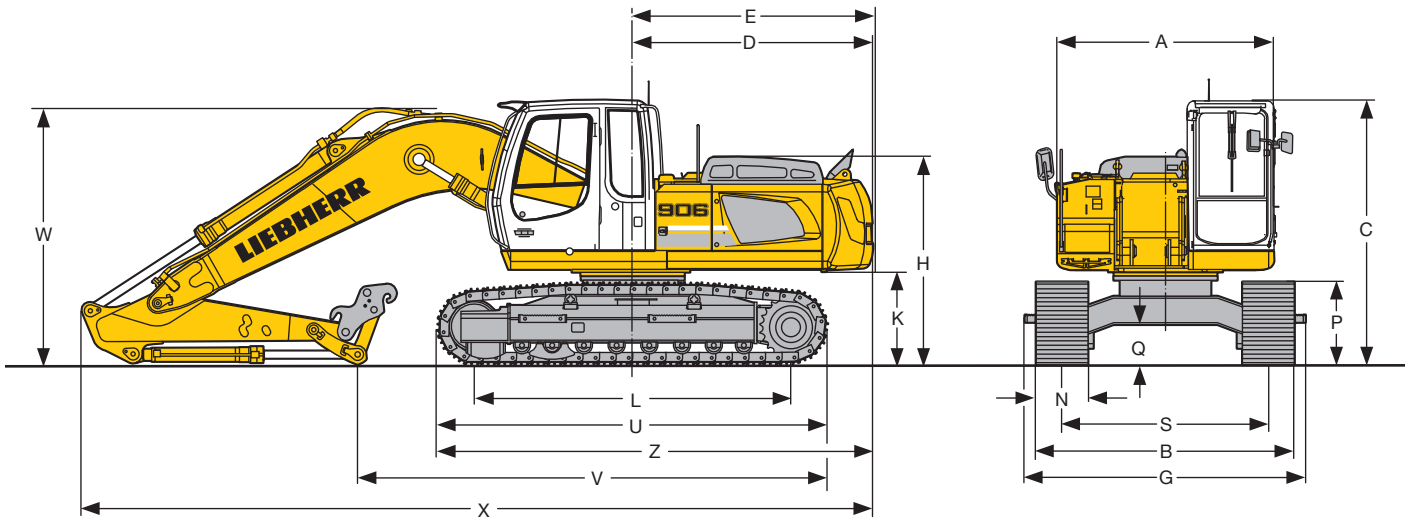

	NLC			LC			WLC		
	mm			mm			mm		
A	2,500			2,500			2,500		
C	3,047			3,047			3,047		
D	2,770			2,770			2,770		
D*	2,770			2,770			2,770		
E	2,790			2,790			2,790		
E*	2,940			2,940			2,940		
H	2,402			2,402			2,402		
K	1,095			1,095			1,095		
L	3,648			3,648			3,648		
P	955			955			955		
Q	460			460			460		
S	2,250			2,000			2,380		
U	4,510			4,510			4,510		
Z	5,180			5,030			5,030		
N	500	600	750	500	600	750	500	600	750
B	2,500	2,600	2,750	2,750	2,850	3,000	2,880	2,980	3,130
G	2,480	2,780	2,780	2,810	2,810	3,110	2,940	2,940	3,240

Mono Boom 5.40 m					
Stick length	m	2.20	2.40	2.70	3.00
V	mm	5,450	5,200	4,950	4,700
W	mm	3,000	3,050	3,050	3,100
X	mm	9,200	9,200	9,200	9,200

Two-piece Boom 3.50 m						
Stick length	m	2.20	2.40	2.70	3.00	
V	mm	6,000	5,900	5,600	5,400	
W	mm	2,700	2,750	2,800	2,850	
X	for NLC-Undercarriage	mm	9,850	9,850	9,850	9,900
	for LC-Undercarriage	mm	9,700	9,700	9,700	9,750
	for WLC-Undercarriage	mm	9,700	9,700	9,700	9,750

* with heavy counterweight

E = Tail radius

G = Width with removable steps

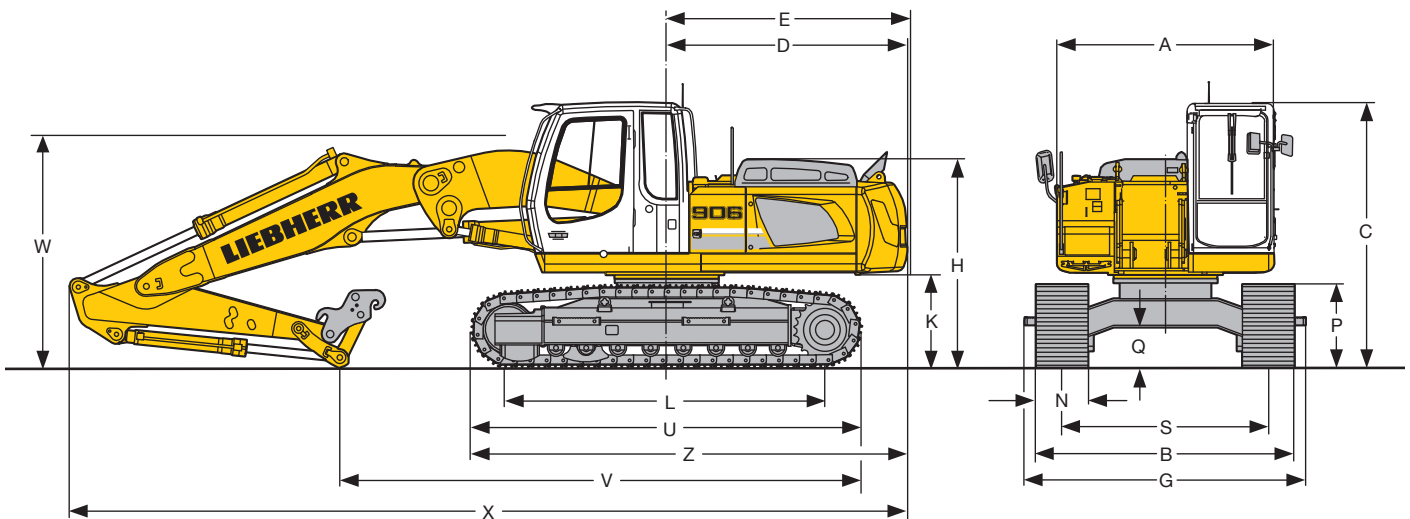

Backhoe Bucket

with Mono Boom 5.40 m

Advanced

Advanced

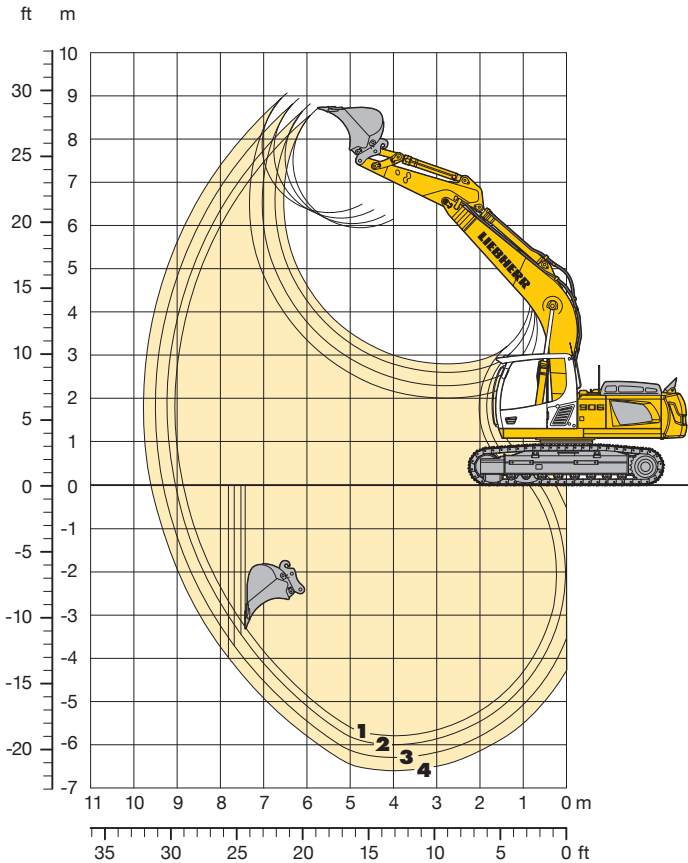

Digging Envelope with Quick Coupler

		1	2	3	4
Stick length	m	2.20	2.40	2.70	3.00
Max. digging depth	m	5.80	6.00	6.30	6.60
Max. reach at ground level	m	8.85	9.05	9.30	9.60
Max. dump height	m	5.95	6.05	6.15	6.30
Max. teeth height	m	8.70	8.80	8.90	9.05

Digging Forces without Quick Coupler

		1	2	3	4
Digging force ISO	kN	134	126	117	108
	t	13.7	12.8	11.9	11.0
Breakout force ISO	kN	158	158	158	158
	t	16.1	16.1	16.1	16.1

with Quick Coupler

Digging force ISO	kN	127	121	112	104
	t	12.9	12.3	11.4	10.6
Breakout force ISO	kN	138	138	138	138
	t	14.1	14.1	14.1	14.1

Operating Weight and Ground Pressure

Operating weight includes basic machine with mono boom 5.40 m, stick 2.20 m, quick coupler 48 and bucket 0.80 m³.

Undercarriage		NLC			LC			WLC		
Pad width	mm	500	600	750	500	600	750	500	600	750
Weight	kg	22,500	22,800	23,250	22,550	22,850	23,300	22,600	22,900	23,350
Ground pressure	kg/cm ²	0.57	0.48	0.39	0.57	0.48	0.39	0.57	0.48	0.39

Optional: heavy counterweight

(heavy counterweight increases the operating weight by 1,000 kg and ground pressure by 0.02 kg/cm²)

Buckets Machine stability per ISO 10567* (75% of tipping capacity)

Cutting width mm	Capacity ISO 7451 m ³	Weight kg	NLC-Undercarriage				LC-Undercarriage				WLC-Undercarriage							
			Stick length (m)				Stick length (m)				Stick length (m)							
			2.20	2.40	2.70	3.00	2.20	2.40	2.70	3.00	2.20	2.40	2.70	3.00				
1,050 ¹⁾	0.80	620	□	□	□	□	□	□	□	□	□	□	□	□	□	□	□	□
1,250 ¹⁾	1.00	720	□	□	△	△	□	□	□	□	□	□	□	□	□	□	□	□
1,400 ¹⁾	1.15	780	□	△	△	■	□	□	□	△	□	□	□	□	□	□	□	□
1,400 ¹⁾	1.35	860	■	■	■	▲	△	△	△	■	□	△	△	△	△	△	△	△
1,050 ²⁾	0.80	630	□	□	□	△	□	□	□	□	□	□	□	□	□	□	□	□
1,250 ²⁾	1.00	730	□	□	△	■	□	□	□	□	□	□	□	□	□	□	□	□
1,400 ²⁾	1.15	790	△	△	■	▲	□	□	△	△	□	□	□	□	□	□	□	△
1,400 ²⁾	1.35	870	■	▲	▲	▲	△	△	■	■	△	△	△	△	△	△	△	■

* Indicated loads are based on ISO 10567 max. stick length, lifted 360° on firm

¹⁾ Bucket without quick coupler

²⁾ Bucket with quick coupler

Other backhoes available on request

Max. material weight □ = ≤ 1.8 t/m³, △ = ≤ 1.5 t/m³, ■ = ≤ 1.2 t/m³, ▲ = not authorized

Backhoe Bucket

with Straight Mono Boom 5.70 m

Advanced

Advanced

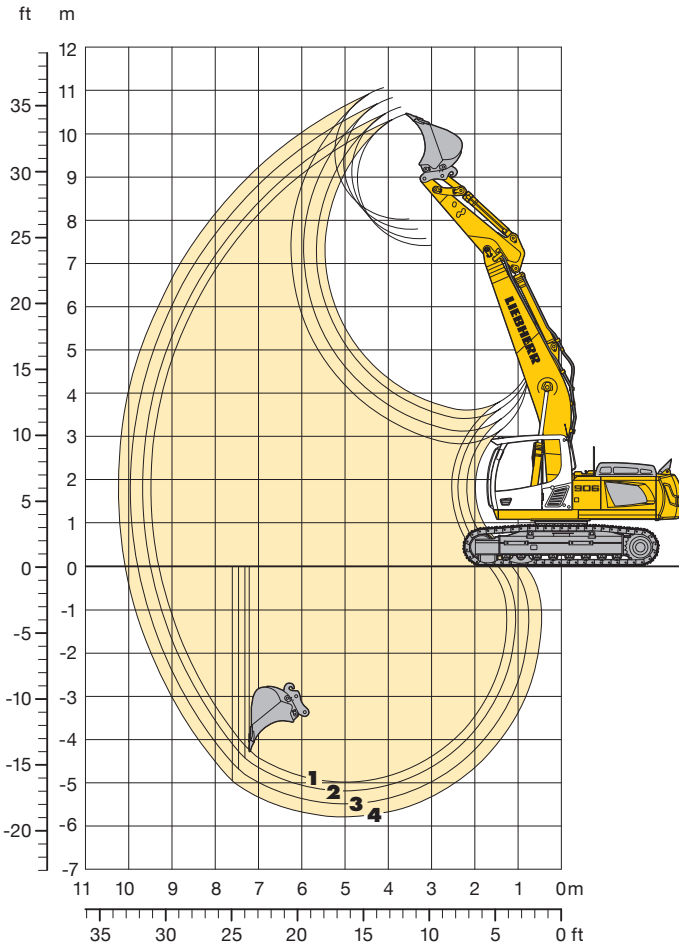

Digging Envelope with Quick Coupler

		1	2	3	4
Stick length	m	2.20	2.40	2.70	3.00
Max. digging depth	m	4.95	5.15	5.45	5.75
Max. reach at ground level	m	9.30	9.50	9.80	10.10
Max. dump height	m	7.40	7.55	7.80	8.00
Max. teeth height	m	10.45	10.60	10.80	11.00

Digging Forces without Quick Coupler

		1	2	3	4
Digging force ISO	kN	134	126	117	108
	t	13.7	12.8	11.9	11.0
Breakout force ISO	kN	158	158	158	158
	t	16.1	16.1	16.1	16.1

with Quick Coupler

Digging force ISO	kN	127	121	112	104
	t	12.9	12.3	11.4	10.6
Breakout force ISO	kN	138	138	138	138
	t	14.1	14.1	14.1	14.1

Operating Weight and Ground Pressure

Operating weight includes basic machine with straight mono boom 5.70 m, stick 2.20 m, quick coupler 48 and bucket 0.80 m³.

		NLC			LC			WLC		
Undercarriage										
Pad width	mm	500	600	750	500	600	750	500	600	750
Weight	kg	22,500	22,800	23,250	22,550	22,850	23,300	22,600	22,900	23,350
Ground pressure	kg/cm ²	0.57	0.48	0.39	0.57	0.48	0.39	0.57	0.48	0.39

Optional: heavy counterweight
(heavy counterweight increases the operating weight by 1,000 kg and ground pressure by 0.02 kg/cm²)

Buckets Machine stability per ISO 10567* (75% of tipping capacity)

Cutting width mm	Capacity ISO 7451 m ³	Weight kg	NLC-Undercarriage				LC-Undercarriage				WLC-Undercarriage			
			Stick length (m)				Stick length (m)				Stick length (m)			
			2.20	2.40	2.70	3.00	2.20	2.40	2.70	3.00	2.20	2.40	2.70	3.00
1,050 ¹⁾	0.80	620	□	□	□	△	□	□	□	□	□	□	□	□
1,250 ¹⁾	1.00	720	□	□	△	■	□	□	□	△	□	□	□	□
1,400 ¹⁾	1.15	780	△	△	■	▲	□	□	△	■	□	□	□	△
1,400 ¹⁾	1.35	860	■	■	▲	▲	△	△	■	▲	△	△	△	■
1,050 ²⁾	0.80	630	□	△	△	△	□	□	□	□	□	□	□	□
1,250 ²⁾	1.00	730	△	△	△	■	□	□	□	△	□	□	□	△
1,400 ²⁾	1.15	790	■	■	■	▲	△	△	△	■	□	□	△	■
1,400 ²⁾	1.35	870	▲	▲	▲	▲	■	■	▲	▲	△	△	■	▲

* Indicated loads are based on ISO 10567 max. stick length, lifted 360° on firm

¹⁾ Bucket without quick coupler

²⁾ Bucket with quick coupler

Other backhoes available on request

Max. material weight □ = ≤ 1.8 t/m³, △ = ≤ 1.5 t/m³, ■ = ≤ 1.2 t/m³, ▲ = not authorized

Backhoe Bucket

with Two-piece Boom 3.50 m

Advanced

Advanced

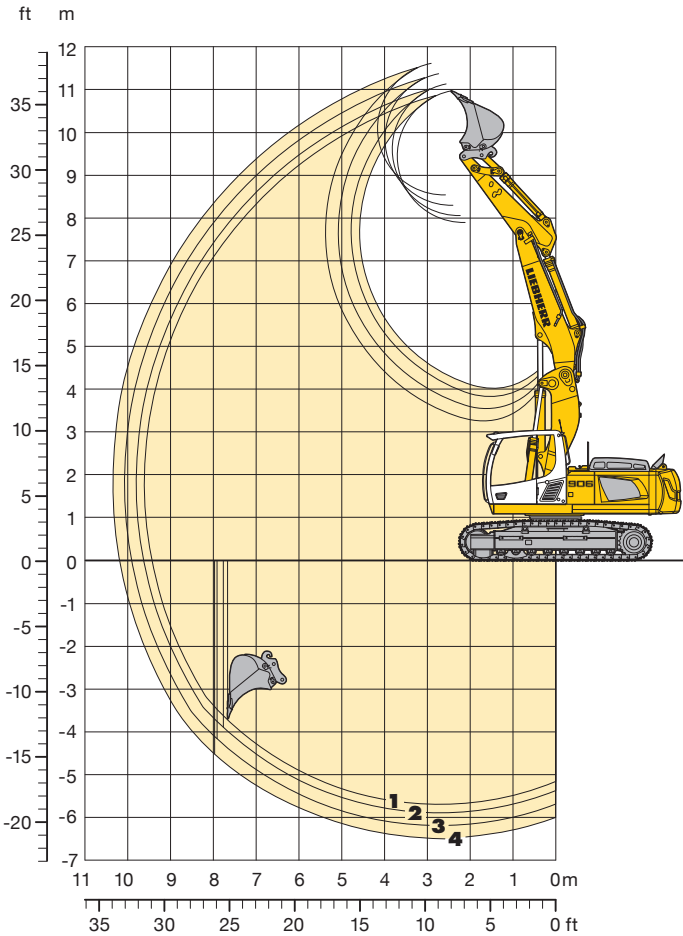

Digging Envelope with Quick Coupler

		1	2	3	4
Stick length	m	2.20	2.40	2.70	3.00
Max. digging depth	m	5.70	5.90	6.20	6.50
Max. reach at ground level	m	9.40	9.60	9.90	10.20
Max. dump height	m	7.90	8.05	8.30	8.50
Max. teeth height	m	10.95	11.10	11.35	11.60

Digging Forces without Quick Coupler

		1	2	3	4
Digging force ISO	kN	134	126	117	108
	t	13.7	12.8	11.9	11.0
Breakout force ISO	kN	158	158	158	158
	t	16.1	16.1	16.1	16.1

with Quick Coupler

Digging force ISO	kN	127	121	112	104
	t	12.9	12.3	11.4	10.6
Breakout force ISO	kN	138	138	138	138
	t	14.1	14.1	14.1	14.1

Operating Weight and Ground Pressure

Operating weight includes basic machine with two-piece boom 3.50 m, stick 2.20 m, quick coupler 48 and bucket 0.80 m³.

		NLC*			LC			WLC		
Undercarriage		500	600	750	500	600	750	500	600	750
Pad width	mm	500	600	750	500	600	750	500	600	750
Weight	kg	24,500	24,800	25,250	23,500	23,800	24,250	23,550	23,850	24,300
Ground pressure	kg/cm ²	0.62	0.52	0.43	0.59	0.50	0.41	0.60	0.50	0.41

* with heavy counterweight

Optional: (for LC-Undercarriage): heavy counterweight (heavy counterweight increases the operating weight by 1,000 kg and ground pressure by 0.02 kg/cm²)

Buckets Machine stability per ISO 10567* (75% of tipping capacity)

Cutting width mm	Capacity ISO 7451 m ³	Weight kg	NLC-Undercarriage with heavy counterweight				LC-Undercarriage				WLC-Undercarriage			
			Stick length (m)				Stick length (m)				Stick length (m)			
			2.20	2.40	2.70	3.00	2.20	2.40	2.70	3.00	2.20	2.40	2.70	3.00
1,050 ¹⁾	0.80	620	□	□	□	□	□	□	□	□	□	□	□	□
1,250 ¹⁾	1.00	720	□	□	△	△	□	△	△	□	□	□	△	△
1,400 ¹⁾	1.15	780	△	△	△	■	△	■	■	□	△	△	△	■
1,400 ¹⁾	1.35	860	■	■	▲	▲	■	■	▲	▲	■	■	■	▲
1,050 ²⁾	0.80	630	□	□	□	△	□	□	△	□	□	□	□	□
1,250 ²⁾	1.00	730	□	□	△	■	□	□	△	■	□	□	△	△
1,400 ²⁾	1.15	790	△	△	■	▲	△	△	■	▲	△	△	■	■
1,400 ²⁾	1.35	870	■	▲	▲	▲	■	■	▲	▲	■	■	■	▲

* Indicated loads are based on ISO 10567 max. stick length, lifted 360° on firm

¹⁾ Bucket without quick coupler

²⁾ Bucket with quick coupler

Other backhoes available on request

Max. material weight □ = ≤ 1.8 t/m³, △ = ≤ 1.5 t/m³, ■ = ≤ 1.2 t/m³, ▲ = not authorized

Backhoe Bucket

with Offset Mono Boom 5.50 m

Advanced

Advanced

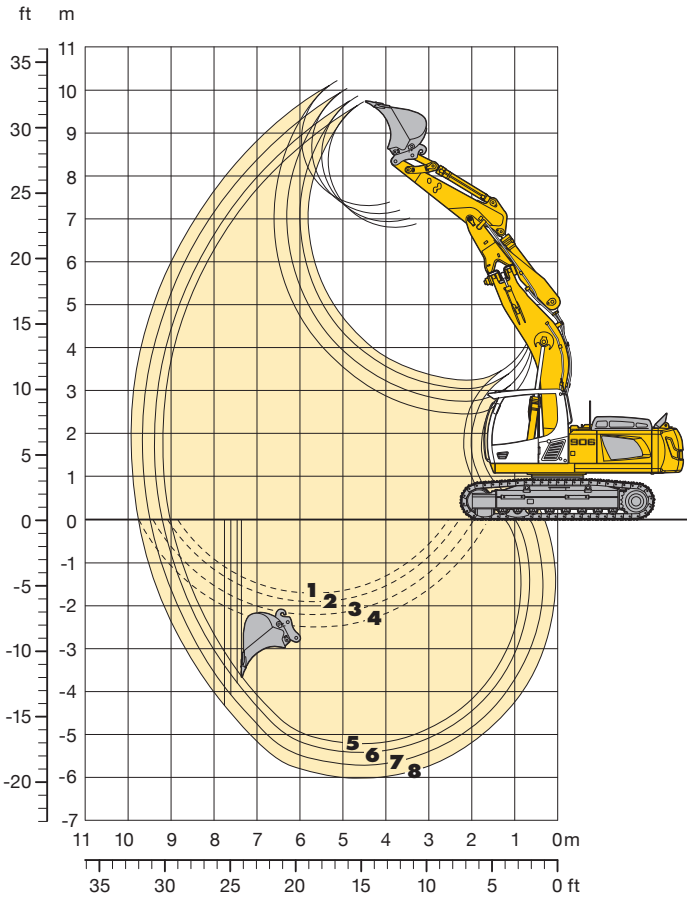

Digging Envelope with Quick Coupler

		5	6	7	8
Stick length	m	2.20	2.40	2.70	3.00
Max. digging depth	m	5.20	5.40	5.70	6.00
Max. reach at ground level	m	9.00	9.20	9.50	9.75
Max. dump height	m	6.80	6.90	7.10	7.30
Max. teeth height	m	9.70	9.85	10.05	10.20

1 Stick 2,20 m, 2 Stick 2,40 m
3 Stick 2,70 m, 4 Stick 3,00 m
at max. attachment offset with vertical ditch walls

Digging Forces without Quick Coupler

Digging force ISO	kN	134	126	117	108
	t	13.7	12.8	11.9	11.0
Breakout force ISO	kN	158	158	158	158
	t	16.1	16.1	16.1	16.1

with Quick Coupler

Digging force ISO	kN	127	121	112	104
	t	12.9	12.3	11.4	10.6
Breakout force ISO	kN	138	138	138	138
	t	14.1	14.1	14.1	14.1

Operating Weight and Ground Pressure

Operating weight includes basic machine with heavy counterweight, offset mono boom 5.50 m, stick 2.20 m, quick coupler 48 and bucket 0.80 m³.

Undercarriage		NLC*			LC			WLC		
Pad width	mm	500	600	750	500	600	750	500	600	750
Weight	kg	24,400	24,700	25,150	23,400	23,700	24,150	23,450	23,750	24,200
Ground pressure	kg/cm ²	0.62	0.52	0.42	0.59	0.50	0.41	0.59	0.50	0.41

* with heavy counterweight

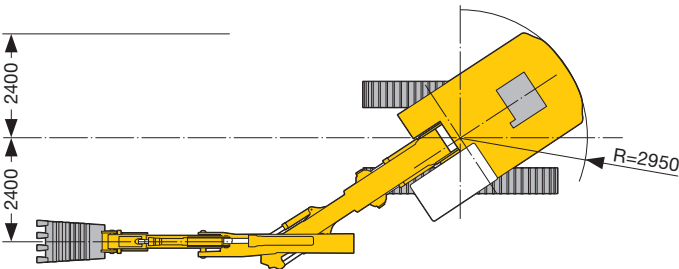

Buckets Machine stability per ISO 10567* (75% of tipping capacity)

Cutting width mm	Capacity ISO 7451 m ³	Weight kg	NLC-Undercarriage with heavy counterweight				LC-Undercarriage				WLC-Undercarriage			
			Stick length (m)				Stick length (m)				Stick length (m)			
			2.20	2.40	2.70	3.00	2.20	2.40	2.70	3.00	2.20	2.40	2.70	3.00
1,050 ¹⁾	0.80	620	□	□	□	□	□	□	□	□	□	□	□	□
1,250 ¹⁾	1.00	720	□	□	□	△	□	□	△	□	□	□	□	□
1,400 ¹⁾	1.15	780	□	△	△	■	□	△	△	■	□	□	△	△
1,400 ¹⁾	1.35	860	△	■	■	▲	△	■	■	▲	△	△	■	■
1,050 ²⁾	0.80	630	□	□	□	□	□	□	□	□	□	□	□	□
1,250 ²⁾	1.00	730	□	□	△	△	□	□	△	△	□	□	□	△
1,400 ²⁾	1.15	790	△	△	■	■	△	△	■	■	□	△	△	■
1,400 ²⁾	1.35	870	■	■	▲	▲	■	■	▲	▲	△	■	■	▲

* Indicated loads are based on ISO 10567 max. stick length, lifted 360° on firm

¹⁾ Bucket without quick coupler

²⁾ Bucket with quick coupler

Other backhoes available on request

Max. material weight □ = ≤ 1.8 t/m³, △ = ≤ 1.5 t/m³, ■ = ≤ 1.2 t/m³, ▲ = not authorized

Backhoe Bucket

with Mono Boom 5.40 m

Classic

Classic

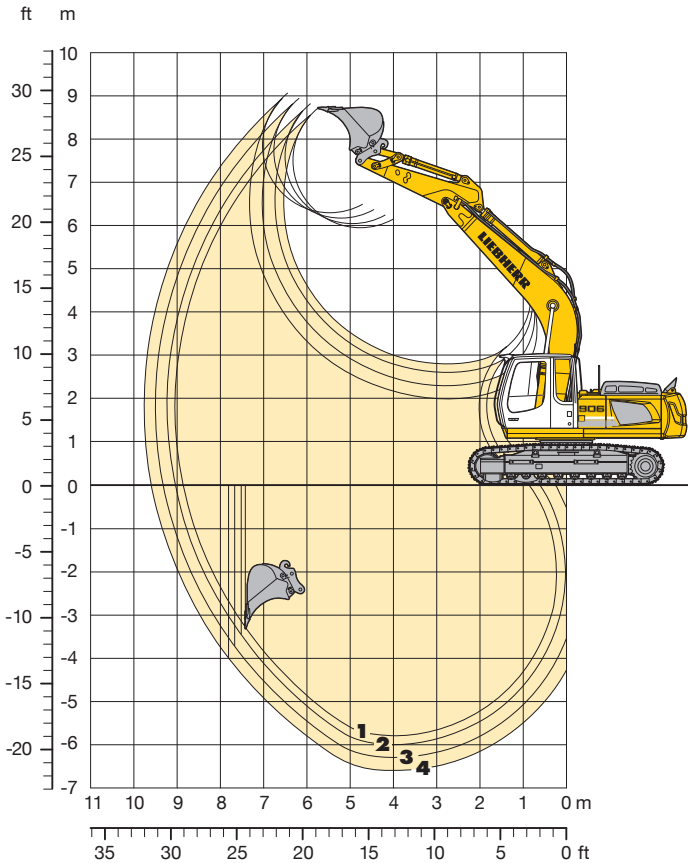

Digging Envelope with Quick Coupler

		1	2	3	4
Stick length	m	2.20	2.40	2.70	3.00
Max. digging depth	m	5.80	6.00	6.30	6.60
Max. reach at ground level	m	8.85	9.05	9.30	9.60
Max. dump height	m	5.95	6.05	6.15	6.30
Max. teeth height	m	8.70	8.80	8.90	9.05

Digging Forces without Quick Coupler

		1	2	3	4
Digging force ISO	kN	128	121	112	104
	t	13.0	12.3	11.4	10.6
Breakout force ISO	kN	152	152	152	152
	t	15.5	15.5	15.5	15.5

with Quick Coupler

Digging force ISO	kN	122	116	107	100
	t	12.4	11.8	10.9	10.2
Breakout force ISO	kN	132	132	132	132
	t	13.5	13.5	13.5	13.5

Operating Weight and Ground Pressure

Operating weight includes basic machine with mono boom 5.40 m, stick 2.20 m, quick coupler 48 and bucket 0.80 m³.

Undercarriage		NLC			LC			WLC		
Pad width	mm	500	600	750	500	600	750	500	600	750
Weight	kg	22,350	22,650	23,100	22,400	22,700	23,150	22,450	22,750	23,200
Ground pressure	kg/cm²	0.57	0.48	0.39	0.57	0.48	0.39	0.57	0.48	0.39

Buckets Machine stability per ISO 10567* (75% of tipping capacity)

Cutting width mm	Capacity ISO 7451 m³	Weight kg	NLC-Undercarriage				LC-Undercarriage				WLC-Undercarriage			
			Stick length (m)				Stick length (m)				Stick length (m)			
			2.20	2.40	2.70	3.00	2.20	2.40	2.70	3.00	2.20	2.40	2.70	3.00
1,050 ¹⁾	0.80	620	□	□	□	□	□	□	□	□	□	□	□	□
1,250 ¹⁾	1.00	720	□	□	□	△	□	□	□	□	□	□	□	□
1,400 ¹⁾	1.15	780	□	△	△	■	□	□	□	△	□	□	□	□
1,400 ¹⁾	1.35	860	■	■	■	▲	△	△	△	■	□	△	△	△
1,050 ²⁾	0.80	630	□	□	□	△	□	□	□	□	□	□	□	□
1,250 ²⁾	1.00	730	□	□	△	■	□	□	□	□	□	□	□	□
1,400 ²⁾	1.15	790	△	△	■	▲	□	□	△	△	□	□	□	△
1,400 ²⁾	1.35	870	■	■	▲	▲	△	△	■	■	△	△	△	■

* Indicated loads are based on ISO 10567 max. stick length, lifted 360° on firm

¹⁾ Bucket without quick coupler

²⁾ Bucket with quick coupler

Other backhoes available on request

Max. material weight □ = ≤ 1.8 t/m³, △ = ≤ 1.5 t/m³, ■ = ≤ 1.2 t/m³, ▲ = not authorized

Backhoe Bucket

with Two-piece Boom 3.50 m

Classic

Classic

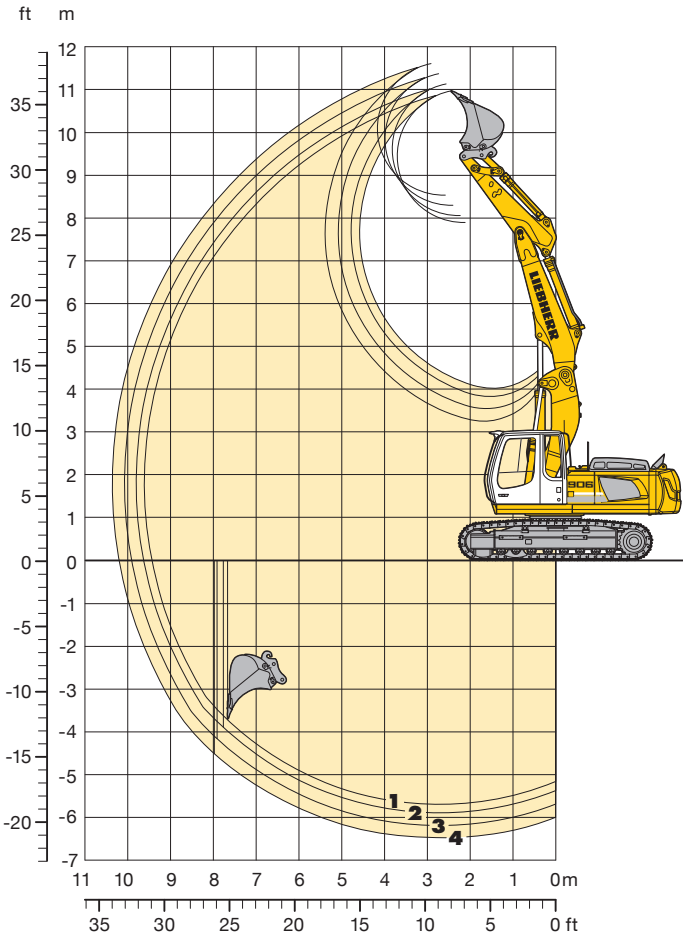

Digging Envelope with Quick Coupler

		1	2	3	4
Stick length	m	2.20	2.40	2.70	3.00
Max. digging depth	m	5.70	5.90	6.20	6.50
Max. reach at ground level	m	9.40	9.60	9.90	10.20
Max. dump height	m	7.90	8.05	8.30	8.50
Max. teeth height	m	10.95	11.10	11.35	11.60

Digging Forces without Quick Coupler

		1	2	3	4
Digging force ISO	kN	128	121	112	104
	t	13.0	12.3	11.4	10.6
Breakout force ISO	kN	152	152	152	152
	t	15.5	15.5	15.5	15.5

with Quick Coupler

Digging force ISO	kN	122	116	107	100
	t	12.4	11.8	10.9	10.2
Breakout force ISO	kN	132	132	132	132
	t	13.5	13.5	13.5	13.5

Operating Weight and Ground Pressure

Operating weight includes basic machine with two-piece boom 3.50 m, stick 2.20 m, quick coupler 48 and bucket 0.80 m³.

Undercarriage		NLC*			LC			WLC		
Pad width	mm	500	600	750	500	600	750	500	600	750
Weight	kg	24,400	24,700	25,150	23,400	23,700	24,150	23,450	23,750	24,200
Ground pressure	kg/cm ²	0.62	0.52	0.42	0.59	0.50	0.41	0.59	0.50	0.41

* with heavy counterweight

Buckets Machine stability per ISO 10567* (75% of tipping capacity)

Cutting width mm	Capacity ISO 7451 m ³	Weight kg	NLC-Undercarriage with heavy counterweight				LC-Undercarriage				WLC-Undercarriage			
			Stick length (m)				Stick length (m)				Stick length (m)			
			2.20	2.40	2.70	3.00	2.20	2.40	2.70	3.00	2.20	2.40	2.70	3.00
1,050 ¹⁾	0.80	620	□	□	□	□	□	□	□	□	□	□	□	□
1,250 ¹⁾	1.00	720	□	□	□	△	□	□	△	△	□	□	□	△
1,400 ¹⁾	1.15	780	△	△	■	■	△	△	■	■	□	□	□	■
1,400 ¹⁾	1.35	860	■	■	▲	▲	■	■	▲	▲	△	■	■	▲
1,050 ²⁾	0.80	630	□	□	□	△	□	□	□	△	□	□	□	□
1,250 ²⁾	1.00	730	□	□	△	■	□	□	△	■	□	□	△	△
1,400 ²⁾	1.15	790	△	△	■	▲	△	△	■	▲	△	△	■	■
1,400 ²⁾	1.35	870	■	▲	▲	▲	■	▲	▲	▲	■	■	▲	▲

* Indicated loads are based on ISO 10567 max. stick length, lifted 360° on firm

¹⁾ Bucket without quick coupler

²⁾ Bucket with quick coupler

Other backhoes available on request

Max. material weight □ = ≤ 1.8 t/m³, △ = ≤ 1.5 t/m³, ■ = ≤ 1.2 t/m³, ▲ = not authorized

Standard Equipment Advanced/Classic



	Advanced	Classic
Undercarriage		
Lifetime-lubricated track rollers	•	•
Tracks sealed and greased	•	•
Track guide at each track frame	•	•
Sprocket with dirt ejector	•	•
Lashing eyes	•	•
Two-stage travel motors	•	•



	Advanced	Classic
Uppercarriage		
Handrails, non slip surfaces	•	•
Engine hood with lift help	•	•
Sound insulation	•	•
Maintenance-free swing brake lock	•	•
Maintenance-free HD-batteries	•	•
Lockable tool box	•	•
Tool kit	•	•



	Advanced	Classic
Hydraulics		
Hydraulic tank shut-off valve and pumps	•	•
Pressure test ports for hydraulic	•	•
Pressure storage for controlled lowering of equipment with engine turned off	•	•
Electronic pump regulation	•	•
Filter with integrated fine filter area (5 µm)	•	•
Stepless work mode selector	•	•
Positive Control Advanced	•	
Positive Control Classic		•
Regeneration Plus function on hydraulic circuit	•	•
Electronic control logic	•	
Hydraulic control logic		•



	Advanced	Classic
Engine		
Turbo charger	•	•
Conform with level IIIA/Tier 3 emission standard	•	•
After-cooled	•	•
Unit pump system injection	•	•
Sensor controlled engine idling	•	•
Dry-type air cleaner w/pre-cleaner, main and safety element	•	•



	Advanced	Classic
Operator's Cab		
Storage bin	•	•
Mechanical hour meters, readable from outside the cab	•	•
Sunroof, right window and windshield with safety glass	•	•
Seat with mechanical suspension	•	•
Control cab Advanced	•	
Completely retractable windscreen	•	
Front windscreen (bottom) retractable	•	
Closed storage space	•	•
Rubber floor mat	•	•
Dome light	•	•
Coat hook	•	•
Automatic air conditioning Classic		•
Automatic air conditioning Advanced	•	
Fuel consumption indicator	•	
Liebherr-Air-Comfort seat heated with air-suspension	•	
Multifunction display		•
7" colour multifunction display with touchscreen	•	
Emergency exit rear window	•	•
Preparation for radio installation	•	•
Right window made of one piece (without post)	•	•
Rain hood over front window opening	•	•
All tinted windows	•	•
Door with sliding window	•	•
Height-adjustable operating console	•	
Seat belt	•	•
Sun roller blind	•	•
Load bearing sectional profile structure, covered with deep-drawn panels	•	•
Wiper/washer	•	•
Cigarette lighter and ashtray	•	•
Two flood lights under rain hood	•	•



	Advanced	Classic
Attachment		
Two separate bearings for hoist cylinder with casted parts	•	
12 t lifting hook with safety link on quick coupler	•	•
Liebherr semi-automatic central lubrication system (except connecting link for bucket kinematics)		•
Liebherr full-automatic central lubrication system (except connecting link for bucket kinematics)	•	
Additional work light on boom (right)	•	•
Cylinders with shock absorbers	•	•

Individual Options Advanced/Classic



	Advanced	Classic
Undercarriage		
Wide step	+	+
Reinforced base panel	+	+
Reinforced cover and base panel	+	+
Three-piece track guide	+	+
Straight track guide	+	+
D6C conversion kit with 3-piece track guide	+	+
Tractive force increase	+	+
NLC-Undercarriage	+	+
LC-Undercarriage	+	+
WLC-Undercarriage	+	+



	Advanced	Classic
Uppercarriage		
Heavy counterweight	+	+
Electric refuel pump	+	+
Reversible fan drive	+	+
Positioning slewing brake	-	+
Customized colors	+	+
Extended tool kit	+	+



	Advanced	Classic
Hydraulics		
Add-on kit rotary drive (including routing)	+	+
Bio-degradable hydr. oil	+	+
Grapple operation (including routing)	+	+
Liebherr proportional control system	+	+
Liebherr Tool-Control	+	+
Bypass filter	+	+
Return filter for hammer	+	+



	Advanced	Classic
Engine		
Fuel pre-heating	+	+
Liebherr particle filter	+	+
Air pre-filter with dust trap	+	+
Automatic engine shut-down (adjustable time-period)	+	+



	Advanced	Classic
Operator's Cab		
Fire extinguisher	+	+
Lower windscreen with wiper	-	+
Foot support	+	+
Electric cool box	+	+
Cab with bullet-proof glass (front and roof windows) and roof window wipers	+	+
LiDAT Standard (Liebherr data transfer system)	+	+
LiDAT Plus (extended Liebherr data transfer system)	+	+
Air pressure operator seat	•	+
Premium operator seat	+	-
Engine shut-down (via push-button) in cab	+	+
Bullet-proof roof glass panel with wiper	+	+
Radio with SD-/MMC-card, Aux-in	+	+
Rear space monitoring with camera	+	+
Beacon	+	+
Wiper for sunroof	+	+
Xenon headlights	+	+
Protective grid up FOPS	+	+
Protective grid front FGPS	+	+
Sun visor	+	+
Roof sun screen	+	+
Auxiliary heating with clock timer	+	+
Change over controls for clamshell bucket/grapple	+	+
Electronic drive away lock	+	+
Additional halogen headlights behind cab	+	+
Additional halogen headlights front cab	+	+



	Advanced	Classic
Attachment		
Two-piece boom	+	+
Offset mono boom	+	-
Hoist cylinder depth limitation	+	+
Security for hoist cylinders	+	+
Piston rod cover bucket cylinder	+	+
12 t lifting hook on bucket	+	+
Liebherr semi-automatic central lubrication system (except connecting link for bucket kinematics)	-	•
Liebherr full-automatic central lubrication system (except connecting link for bucket kinematics)	•	+
LIKUFIX	+	+
Liebherr line of buckets	+	+
Straight mono boom	+	+
Safety check valves hoist cylinder	+	+
Safety check valves stick cylinder	+	+
Hose-protecting lubrication system (stick rear)	+	+
Hydr. or mechanical quick coupler	+	+
Overload warning device	+	+
Central lubrication of the connecting link for bucket kinematics	+	+
Working headlight on boom (left)	+	+

Advanced/Classic

• = Standard, + = Option, - = not available

Option Packages Advanced/Classic

Advanced/Classic

	Advanced	Classic
Anti-Theft Package	+	+
Electronic drive away lock		
Fuel anti-theft device		
Lighting Package	+	+
Headlights on cab (Xenon, 2 pieces)		
Additional rear headlights on cab (2 pieces)		
Travel-Safety Package	+	+
Add-on exterior mirror right		
Beacon		
Travel-Safety Package Plus	+	+
Travel alarm system in right joystick (switchable)		
Add-on exterior mirror right		
Beacon		
Add-On Package – Hammer Classic	-	+
Security for hoist cylinder for hammer operation		
Return filter for hammer		
Add-On Package – Hammer Advanced	+	-
Security for hoist cylinder in grab or hammer operation (switchable)		
Return filter for hammer		
Add-On Plus Package – Hammer Classic	-	+
Cab with bullet-proof glass (front and roof windows) and roof window wipers		
Security for hoist cylinder for hammer operation		
Return filter for hammer		

	Advanced	Classic
Add-On Plus Package – Hammer Advanced	+	-
Cab with bullet-proof glass (front and roof windows) and roof window wipers		
Security for hoist cylinder in grab or hammer operation (switchable)		
Return filter for hammer		
Heavy Duty Package Classic	-	+
Protection for stick		
3-piece track guide		
Heavy Duty Package Advanced	+	-
Protection for stick		
Piston rod guard for bucket cylinder		
Reinforced base panel		
Cab with bullet-proof glass (front and roof windows) and roof window wipers		
Three-piece track guide		
Heavy Duty Package Plus Advanced	+	-
Protection for stick		
Piston rod cover bucket cylinder		
D6C conversion kit with 3-piece track guide		
Reinforced base panel		
Cab with bullet-proof glass (front and roof windows) and roof window wipers		
Protective grid up FOPS		
Protective grid front FGPS		

• = Standard, + = Option, - = not available

Option Packages Advanced/Classic

	Advanced	Classic
Cold Climate Start Package Auxiliary heater with weekly timer Fuel pre-heating	+	+
Comfort Package Extended tool equipment Radio with SD-/MMC-card, Aux-in Electric cool box	+	+
Comfort Package Plus Classic Extended tool equipment Radio with SD-/MMC-card, Aux-in Electric cool box Air pressure operator seat Sun visor Foot support	-	+
Comfort Package Plus Advanced Extended tool equipment Radio with SD-/MMC-card, Aux-in Electric cool box Premium operator seat Sun visor Foot support	+	-

	Advanced	Classic
Add-On Light Package 2 additional rear headlights on cab Additional working headlights on boom	+	+
Add-On Light Package Plus 2 additional headlights on cab 2 additional rear headlights on cab 1 additional working headlights on boom	+	+
EU Lift Capacity Package Apave Europe Hoist cylinder load holding valves Lift capacity table Overload warning device	+	+
Adjustable Boom Package Adjustable attachment Hoist limitation in depth	+	-

Advanced/Classic

• = Standard, + = Option, - = not available

Options and/or special attachments, supplied by vendors other than Liebherr, are only to be installed with the knowledge and approval of Liebherr in order to retain warranty.

The Liebherr Group of Companies



Wide Product Range

The Liebherr Group is one of the largest construction equipment manufacturers in the world. Liebherr's high-value products and services enjoy a high reputation in many other fields. The wide range includes domestic appliances, aerospace and transportation systems, machine tools and maritime cranes.

Exceptional Customer Benefit

Every product line provides a complete range of models in many different versions. With both their technical excellence and acknowledged quality, Liebherr products offer a maximum of customer benefits in practical application.

State-of-the-art Technology

To provide consistent, top quality products, Liebherr attaches great importance to each product area, its components and core technologies. Important modules and components are developed and manufactured in-house, for instance the entire drive and control technology for construction equipment.

Worldwide and Independent

Hans Liebherr founded the Liebherr family company in 1949. Since that time, the enterprise has steadily grown to a group of more than 120 companies with over 35,000 employees located on all continents. The corporate headquarters of the Group is Liebherr-International AG in Bulle, Switzerland. The Liebherr family is the sole owner of the company.

www.liebherr.com