

MLT 735

AGRICULTURAL HANDLING solutions



 **MANITOU**

www.manitou.com

A PASSION FOR FARMING



As partners to the farming industry for more than 20 years, we know your business is **demanding**, and on today's modern farm the materials handling plays an important part in the daily farm handling jobs, so you can be sure you'll be able to find within our farming range **THE MANITOU** you need.

The MLT 735 rough terrain telehandler is the ideal choice for **performance**. Its impressive capabilities enable you to carry out all your **farm handling** tasks:

animal feed, harvesting work, bulk loading and unloading, etc.

Arable, dairy and livestock farmers, cereal growers, cooperatives and agricultural contractors will appreciate the qualities of this machine. More than just a handling solution, MANITOU offers you a product which both looks good and is comfortable to use: inside and outside have been cleverly designed to satisfy you. The MLT 735 benefits from innovations such as: JSM^{®*}, Evolution cab, ECS^{**} ...

In short you gain in both **comfort** and **productivity**.

When you choose MANITOU, you can count on a fork lift truck for long term durability. You also benefit from the package of services provided by your dealer: after-sales service, servicing and maintenance contracts, on-site repairs and financing solutions, etc.

Why all this? Because, like you, we take pleasure in a **job well done!**



* Joystick Switch and Move, patent applied for by MANITOU BF
** Easy Connect System: hydraulic decompression of the accessory line



“A real agricultural
handling **solution**”



PERFORMANCE ON YOUR FARM

Up to 3.5 T:

The dimensions and wheelbase of the MLT 735 mean that loads of up to 3.5 T can be handled in complete safety.

6.90 m:

The boom of your MLT lets you carry loads up to 6.90 m in height.

24 inch:

The agricultural profile tyres give your machine total adhesion on all types of terrain.



You choose

The MLT 735 comes with a 121 HP engine coupled to a four-speed manual gearbox or 6-speed Powershift and a 150 l/min variable flow rate pump.



Style and design

Because you appreciate machines that look good, the design of the MLT 735 has been carefully worked on. Its style is marked by delicate lines and slender shapes... you're hooked straight away.

Goes anywhere

Agricultural profile tyres, high ground clearance (44 cm) and an impressive tractive effort will ensure you can work on the most difficult ground conditions. The MLT 735 has been developed to help you manage your everyday farm duties.



YOU FEEL GOOD...



Farming has changed a lot, handling as well.

The interior of the MLT leaves nothing to be desired with its superb bodywork. The driving position has been **ergonomically designed** for maximum comfort. It is fitted with a cloth seat and the fully adjustable steering column can be adapted to suit. Ventilation outlets, sun visor, roof screen, etc. all help to provide you with a comfortable working environment.

Exclusive to MANITOU, **JSM®** lets you control all movements with one hand safely and effortlessly: raising and lowering the boom, crowding and tilting, auxiliary service for operating attachments and also forward/reverse direction of travel. You always keep one hand on the steering wheel to maintain full control of your MLT.

Low noise levels are achieved through the full **soundproofing** of the cab (only 76 dB) and the insulation of the engine compartment.

The dashboard has an analogue display which gives all the information you need during your working day: hour meter, speed, oil temperature, fuel level, etc.

For still more comfort, the Evolution cab gives you all the space you need to feel comfortable throughout the working day.



“... but you have to
go home in the end!”



“Adapting to your requirements”



EACH TO THEIR OWN **STYLE**

Reacting to customer choice is a MANITOU principle. That's the reason you **can choose between** 3 levels of finish: **Classic**, **Premium** and **Elite**.

Because all your requirements are important, MANITOU provides you with complete peace of mind in all versions of the MLT.



CLASSIC

In the **Classic** version, your comfort is increased by:

- Mechanical cloth seat
- Rear-view mirror
- Radio player
- Radiator auto cleaning system

PREMIUM

You are not just opting for a MANITOU, but for **your** MANITOU...
The **Premium** finish is differentiated by a number of practical and innovative items:

- Pneumatic cloth seat
- Rear-view mirror
- CD/MP3 car radio
- Air conditioning
- Attachment line decompression system: Easy Connect System
- Radiator auto cleaning system

ELITE

The **Elite** version offers a top specification model:

- Low-frequency pneumatic cloth seat
- Rear-view mirror
- Bluetooth car radio
- Air conditioning
- Boom suspension
- Attachment line decompression system: Easy Connect System
- Self-cleaning pre-filter
- Radiator auto cleaning system

DESIGNED TO OPTIMISE POWER AND FUEL EFFICIENCY



Each telehandler must have a **suitable power unit** to give you the best engine/machine torque: too little power and you lose efficiency, too much power could increase consumption to no effect.

The MLT 735 is supplied with a **MERCEDES 4.2 I, 121 HP**, four-cylinder turbo engine. Providing you with the capacities required and an ideal power/weight ratio, this engine will support you in everything you do.

All the major components of your machine (power unit, transmission, axles, hydraulics and tyres) are combined in such a way as to optimise the power produced by your engine.

121 HP:

The Mercedes engine offers an ideal power/weight ratio. The 121 HP available provide you with efficient daily fuel consumption.

4- or 6-speed gearbox:

You will find the gearbox suited to your needs: 4-speed mechanical or 6-speed Powershift.

“**Optimising**
the power of
your **engine**”





**“Work quickly
and effectively”**

YOU WILL HAVE TIME TO SPARE

Save yourself time to concentrate on what matters - that's MANITOU's philosophy when it comes to handling: fast working cycles and driver comfort are good examples.

For maximum efficiency, MANITOU offers you a machine which is simple to use. **Quick and easy to learn** (JSM[®], controls perfectly placed), your machine is the solution to all your farm handling duties.

Manoeuvrability is essential! With your MLT 735, you will be able to do even more work: the more time you spend at the wheel the more your efficiency will be increased.

Your productivity and safety is greatly enhanced by a wide range of attachments which increases the performance and overall utilisation of your machine. The development of our machinery with approved accessories optimises your work cycles while respecting all relevant industry standards. An extensive choice of attachments from bale clamp, buckets, manure forks, feeding bucket and sweepers... MANITOU is with you to meet all your needs.



Loading comparison data

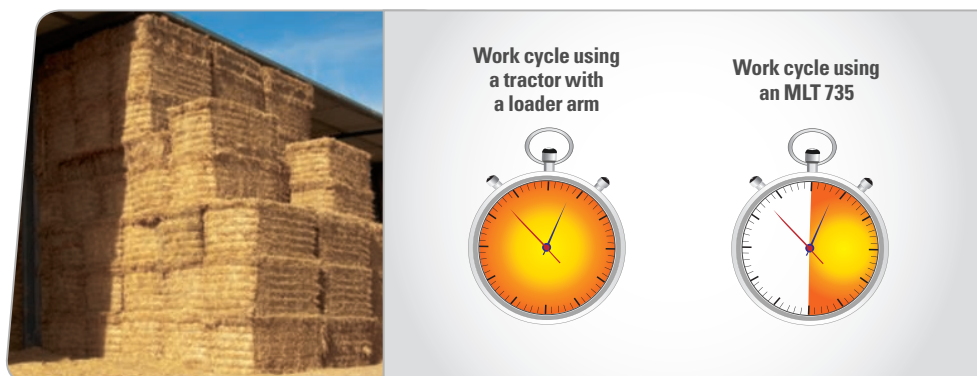

Sources: Data MANITOU

150 l/min:

The hydraulic pump of your MLT, combined with the JSM[®], delivers a maximum flow rate of 150 l/min for quick and accurate movements.

4 x 4 x 4:

4 wheel drive and 4 wheel steer = manoeuvrability for getting out of all situations.

YOU ARE **SAFE**

SORRY, WE DON'T DESIGN TOYS

Our **design department**, employing more than 200 engineers and technicians, have specialised in the design of agricultural telehandlers **for more than 20 years**. With more than 50 registered patents, our knowledge and expertise with regard to the structure of the machine offers you reliability and durability. A fully comprehensive testing procedure and «best practice» methods are applied to ensure quality manufacturing at all levels, utilising all the latest modern technology.

Specialists in agriculture, MANITOU develop their product range with the customer in mind, selecting components to suit the most arduous farm handling needs, **your machine like the MANITOU company is 100% dedicated to agriculture**: the tyres, transmission and even the cooling system have been logically chosen and assembled.

**“A machine
100% dedicated to
agricultural use”**



YOU ARE PROTECTED

Your working environment must above all be a safe area.

The excellent **stability** of the MLT 735 combined with the aggravating movement arrestor allows you to handle maximum loads up to **3.5 tonnes** with complete confidence.

Your **safety** is further reinforced by the **presence detector** located in the seat. Travel movements are only allowed when you are sitting in the driving seat.

The cab has been especially designed to **protect** you. Satisfying **ROPS/FOPS*** requirements, withstanding rolling over, heavy objects falling and therefore prevents distortion to the cab.

A large window area, **lateral engine**, low boom pivot as well as the high seating position gives you **360° visibility** guaranteeing both your own safety and that of everyone around you.

* ROPS: rollover protection structure
FOPS: falling objects protection structure

“The assurance of working
in total safety”



SEE FURTHER

OFFERING YOU **MADE-TO-MEASURE SERVICES**

The close proximity of a network of experts at your service.

Your local MANITOU dealer is dedicated to providing a first class after sales back up. The know-how, experience and commitment of MANITOU, at more than 500 dealers throughout the world, ensure you will have professional support on a daily basis.

Lease and Finance Solutions. Your MANITOU dealer is your best partner to assist you in your financial planning. Manitou Finance offer a fully flexible choice of financial solutions.

Maintenance and after-sales service: so that your telehandler is operational all year round, your dealer can offer you maintenance contracts suited to your budget and your needs. You will reduce your usage costs and have the guarantee of your equipment being regularly monitored. MANITOU is committed to maintaining your productivity on a daily basis.



A financial contract allowing you to be aware in advance of the technician's labour and travel costs for preventive maintenance of your machine (parts and supplies not included in the contract).



Maintenance contract which includes the totality of the cost of preventive maintenance for your machine -labour, travel, supply of consumables needed for periodic maintenance.

MANIPLUS Agri

You can sign up for an extension of guarantee of 12 or 24 months.



A simple and flexible fleet-management system (with or without geolocation) to keep track with precision of the utilisation of your machine.



“Accompanying
the changes in
your business”



REDUCE YOUR ECOLOGICAL FOOTPRINT

From the design stage of your machine, MANITOU does everything to **respect the environment**.



Our Ancenis production site, certified **ISO 14001***, guarantees that environmental standards are included from the design stage of the product up to the delivery of the machine to your business. Daily routine procedures include the selection of the least polluting components, selective sorting, treatment of special wastes and quite simply daily vigilance (energy, paper savings, etc.).

The optimum management of the engine speed according to the power demanded **minimises your consumption** and your polluting emissions, thus reducing the impact of the use of your MLT on the environment.

* ISO 14001: international environmental management standard which lays down requirements relating to the implementation of an environment management system.



YOU CHOOSE

| Standard and optional equipment |  CLASSIC |  PREMIUM |  ELITE |
|------------------------------------|---|---|---|
| Fork carriage | ● | ● | ● |
| Straw deflector | ● | ● | ● |
| Rear-view mirror | ● | ● | ● |
| Radiator auto cleaning system | ● | ● | ● |
| Radio player | ● | - | - |
| CD/MP3 car radio | ○ | ● | - |
| Bluetooth car radio | ○ | ○ | ● |
| Mechanical cloth seat | ● | - | - |
| Pneumatic cloth seat | ○ | ● | - |
| Low-frequency pneumatic cloth seat | ○ | ○ | ● |
| Air conditioning | ○ | ● | ● |
| Easy Connect System | ○ | ● | ● |
| Boom suspension | ○ | ○ | ● |
| Self-cleaning pre-filter | ○ | ○ | ● |
| Hydraulic locking (accessories) | ○ | ○ | ○ |
| TURBO II pre-filter | ○ | ○ | ○ |
| Reversing warning buzzer | ○ | ○ | ○ |
| Internal rear-view mirror | ○ | ○ | ○ |

● Standard ○ Option - Not available

A selection of attachments available:

| | | |
|---|---|---|
|  |  |  |
| Multifunction grab bucket | Light Material Bucket | Collector brush |
|  |  |  |
| Bale clamp intensive | Silo unloader-distributor bucket | HP self washer |

MLT 735

| | MLT 735-120 | MLT 735-120 PS |
|--|--|---|
| | Lifting capacity at 500 mm from fork heels | 3500 kg |
| | Break-out force | 3700 daN |
| | Lifting height | 6.90 m |
| | Time: laden/unladen (in sec) | |
| | Lifting | 6.70/7.30 |
| | Lowering | 4.80/4.60 |
| | Extension | 7.10/7.30 |
| | Retraction | 5.70/5.50 |
| | Dump | 2.35 |
| | Tyres | 460/70 R24 |
| | Forks | |
| | Length x width x thickness | 1200 x 125 x 45 mm |
| | Carriage rotation | 146° |
| | Braking | multiple-disk brake with oil bath on front and rear axles |
| | MERCEDES STAGE III A engine | OM-904LA |
| | Cubic capacity | 4 cyl. Turbo/4250 cm ³ |
| | Power at 2200 rpm (ISO/TR 14396) | 121 HP/90 kW |
| | Max. torque from 1200 to 1600 rpm (ISO/TR 14396) | 470 Nm |
| | Injection | direct |
| | Cooling | water |
| | Transmission | torque converter |
| | Gearbox | Powershuttle Powershift |
| | Number of gears (forward/reverse) | 4/4 6/3 |
| | Max. travel speed | 35 kph* 40 kph* |
| | Hydraulics | 150 l/min - 270 bar |
| | Piston pump | electronically controlled variable cubic capacity |
| | Control valve | DDIC |
| | Capacities | |
| | Hydraulic oil | 135 l |
| | Fuel | 120 l |
| | Unladen weight (with forks) | 7154 kg |
| | Width overall | 2.40 m |
| | Height overall | 2.30 m |
| | Length overall | 4.79 m |
| | Turning radius (outer wheels) | 3.77 m |
| | Ground clearance | 0.44 m |
| | Drawbar pull | 7280 daN |
| | Noise at driving position (LpA) | 76 dB |
| | Environmental noise (LwA) | 107 dB |
| | Vibration to whole hand/arm | < 2.5 m/s ² |

Maximum height reach: 1.03 m

As per standard EN 1459 annex B

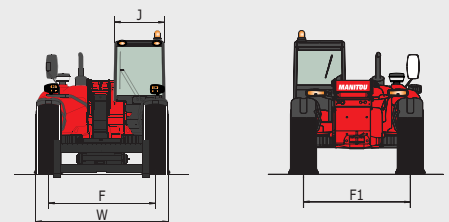
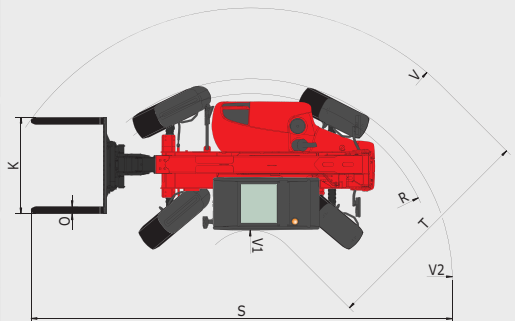
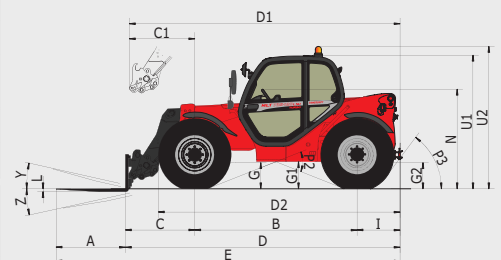
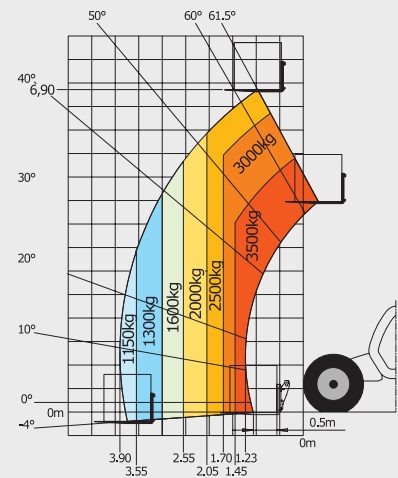

| | | | | | | | | | |
|-----------|--------|-----------|--------|-----------|------|-----------|--------|-----------|--------|
| A | 1200 | D2 | 4165 | I | 789 | P3 | 53° | V1 | 1310 |
| B | 2810 | E | 5990.4 | J | 980 | R | 3685 | V2 | 3918.5 |
| C | 1191.4 | F | 1935 | K | 1260 | S | 7714.9 | W | 2402 |
| C1 | 1287 | F1 | 1935 | L | 45 | T | 3575 | Y | 12.5° |
| D | 4790.4 | G | 450 | N | 1715 | U1 | 2295 | Z | 133.7° |
| D1 | 4886 | G1 | 435 | O | 125 | U2 | 2545 | | |
| | | G2 | 435 | P2 | 38° | V | 4885 | | |

This brochure describes versions and configuration options for Manitou products which may be fitted with different equipment. The equipment described in this brochure may be standard, optional or not available depending on version. Manitou reserves the right to change the specifications shown and described at any time and without prior warning. The manufacturer is not liable for the specifications given. For more information, contact your Manitou dealer. Non-contractual document. Product descriptions may differ from actual products. List of specifications is not comprehensive. The logos and visual identity of the company are the property of Manitou and may not be used without authorisation. All rights reserved. The photos and diagrams contained in this brochure are provided for information only.

MANITOU BF SA - Limited company with board of directors - Share capital: 39,547,824 euros - 857 802 508 RCS Nantes



Your nearest **MANITOU** dealer:



Head office:
B.P. 249 - 430 rue de l'Aubinière - 44158 Ancenis Cedex - France
Tel: 00 33 (0)2 40 09 10 11 - Fax: 00 33 (0)2 40 09 10 97
www.manitou.com