

BACKHOE LOADER

TRIS 10.33



officine
PICCINI®

BACKHOE LOADER

TRIS 10.33

Technical information



Diesel Engine

Item and type	Perkins 1004-4T turbo
Max. power DIN 760020	84 kW - 114 CV - 2600 rpm
Max. power 80/1269 CEE	78.5 kW - 106.6 CV - 2500 rpm
Displacement	3990 cm ³
Cylinders	4
Cooling system	Water with antifreeze

Transmission

Type: hydrostatic	Variable flow pump, hydraulic engine with two displacements mechanic gear reducer with two ratios by electro-hydraulic control
Speeds : n° 4	Working: slow 0 ÷ 5 km/h; fast 0 ÷ 11 km/h; Traveling: slow 0 ÷ 15 km/h fast 0 ÷ 33 km/h

Chassis and steering

Chassis	Articulated and center jointed, ball joints system opt. oscillation blocking system by electro-hydraulic control DBS
Oscillation angle	20°
Steering angle	80°
Steering	Hydro-steering working on two cylinders

Axles and tyres

Axles	Rigids with planetary reducers; opt. differential lock 100%
Tyres	405/70-24 14PR

Brakes

Service	Disk type in oil bath on rear axle opt. on both axles
Emergency and parking	Disks type on mechanic gear

Electric system

Batteries	n° 2; 12V - 80 Ah
Alternator	12V - 55 Ah

Hydraulic system

Pump	Gears type with priority valve Load Sensing
Max. flow	120 l/min
Working pressure	190 bar
Control valves	Flow Sensing

Refueling

Fuel	120 litres
Engine oil	10 l
Coolant system	16 l
Hydraulic oil	150 l

Loader specifications

Bucket max capacity (CECE)	1.2 m ³
Bucket width	2200 mm
Useful load	3400 kg
Breakout force	7500 kg
Total mass	7500 kg

Backhoe FE 4.70 specification

Max. excavation depth	4680 mm
Useful excavation depth	4240 mm
Max. excavation distance	5345 mm
Breakout force	6100 kg
Useful load	2450 kg
Buckets width	300 ÷ 800 mm
Translation lock	Hydraulic

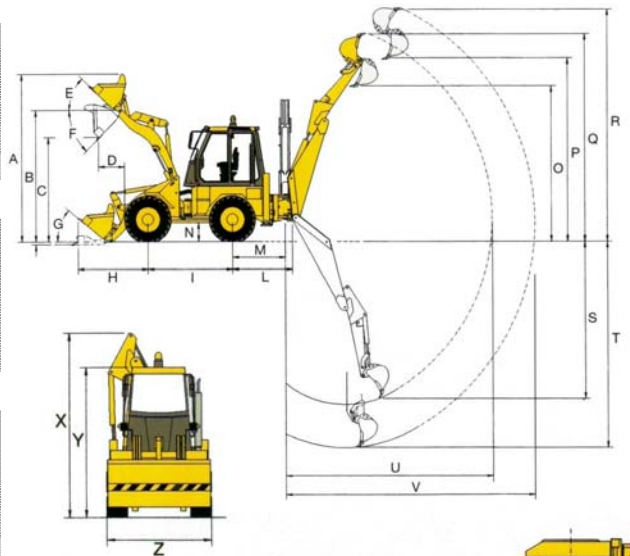

A	4290 mm
B	3390 mm
C	2720 mm
D	740 mm
E	45°
F	45°
G	45°
H	1830 mm
I	2220 mm
L	1650 mm
M	1370 mm
N	430 mm
X	3630 mm
Y	2940 mm
Z	2200 mm
J	1980 mm
J'	4030 mm
K	4500 mm
AA	40°

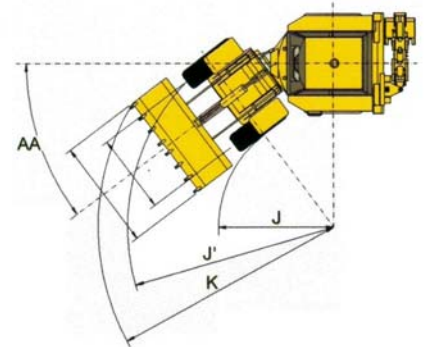

BACKHOE		
	STANDARD	TELESCOPIC
O	3990 mm	-
P	-	4700 mm
Q	5310 mm	-
R	-	5950 mm
S	4240 mm	-
T	-	5250 mm
U	5340 mm	-
V	-	6280 mm



S.S. Trasimeno Ovest 161/c
06132 Perugia -Italy
Tel. +39 075 51801 - Fax +39 075 5179166
Web Site: www.officinepiccini.it
E-Mail: info@officinepiccini.it

Vendite Italia 075 5180239
Assistenza 075 5180221
Export Sales +39 075 5180240
Service +39 075 5180221

BACKHOE LOADER

TRIS 10.33

Informations techniques



Moteur

Marque et type	Perkins 1004-4T turbo
Puissance maxi DIN 760020	84 kW-114 CV à 2600 t/min
Puissance maxi réglage	78.5 kW - 2500 Umin (80/1269 CEE)
Cylindrée	3990 cm ³
Cylindres	4
Fieffroidissement	Eau et antiglace

Transmission

Type: hydrostatique	Pompe a debit variable, moteu avec deux cytrindrées, command électrique boîte de vitesse à deux rapports par command électrohydraulique
Vitesses : n` 4	Travail: lente 0 ÷ 5 km/h; rapide >11 km/h. Transfertement: lente 0 ÷ 15 km/h rapide 0 ÷ 33 km/h

Chassis et direction

Chassis	Aniculé et denoyé au centre. s'stème par joints a rotule opt. dispositif de blocage DBS par command élec-trohydraulique
Angle d'oscillation	20°
Angle d'articulation-direction	80°
Direction	Assistée: hydroguide agissante sur deux vérins a double effect

Essieux et pneus

Essieux	Rigides avec réducteurs planetaires; opt. blocage différentiel arrière 100%
Pneus	405/70-24 14PR

Freins

De service	A disc immergé sur l'essieu arrière; opt. sur les deux essieux
De secours et parc	A disques dans la boîte de vitesse

Système électrique

Batteries	n ° 2.12 V - 80 Ah
Alternateur	12 V - 55 Ah

Système hydraulique

Pompe	A engrenages avec valve diviseuse a debit prioritaire Load Sensing
Debit maxi	120 l/min
Pression de travail	190 bar
Distributeurs	Flow Sensing

Ravitaillements

Carburant	120
Huile moteur	10
Refroidissement moteu	16
Huile hydraulique	150

Donnés chargeuse

Capacité maxi godet (CECE)	1.2 m ³
Largeur godet	2200 mm
Charge utile	3400 kg
Force de cavage	7500 kg
Poids avec pelle	7500 kg

Donnés pelle retro FE 4.70

Profondeur maxi de creusage	4680 mm
Profondeur utile de creusage	4240 mm
Distance maxi de creusage	5345 mm
Charge utile	2450 kg
Force de cavage	6100 kg
Largeur godets	300 ÷ 800 mm
Blocage de la translation	Hydraulique

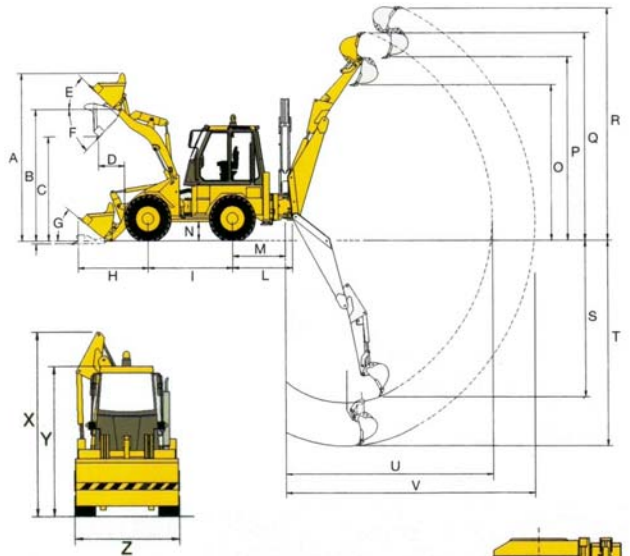

A	4290 mm
B	3390 mm
C	2720 mm
D	740 mm
E	45°
F	45°
G	45°
H	1830 mm
I	2220 mm
L	1650 mm
M	1370 mm
N	430 mm
X	3630 mm
Y	2940 mm
Z	2200 mm
J	1980 mm
J'	4030 mm
K	4500 mm
AA	40°

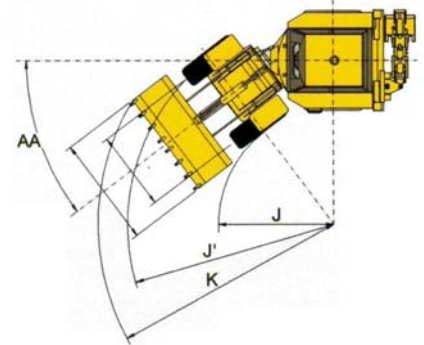

BACKHOE	
STANDARD	TELESCOPIC
O	3990 mm
P	4700 mm
Q	5310 mm
R	5950 mm
S	4240 mm
T	5250 mm
U	5340 mm
V	6280 mm



S.S. Trasimeno Ovest 161/c
06132 Perugia -Italy
Tel. +39 075 51801 - Fax +39 075 5179166
Web Site: www.officinepiccini.it
E-Mail: info@officinepiccini.it

Vendite Italia 075 5180239
Assistenza 075 5180221
Export Sales +39 075 5180240
Service +39 075 5180221