

**MS2 PICKUP MACHINE****MS2 PICKUP MACHINE****Features:**

- 121 hp (90 kW) Tier 3 diesel engine
- 1,320 tons/hr (1,199 t/hr) max capacity
- Variable hydraulic elevator drive
- Hydraulic leveling
- Adjustable front scraper blade
- Transportable on 8 ft (2,400 mm) trailer

## MS2 Pickup Machine Specifications

Attaching the MS2 Pickup Machine to a Terex® paver maximizes production levels and improves overall mat quality. The MS2 eliminates many of the problems associated with traditional stop-and-go paving practices. Increase production levels further by adding a paver hopper insert, which provides additional surge capacity and increases material flow. MS2 Pickup Machines have the lowest maintenance costs of any similar product in the industry.

### Standard Features

Dual elevator roller chains with bolt-on flights
Variable hydrostatic drive
Two planetary gear boxes and drive mount motors on head shaft
High-alloy floor liners
Segmented head shaft sprockets and tail shaft idlers
Reversible elevator to clear obstructions
Double seal on head shaft gearbox
Adjustable front scraper blade
Rear wheel width allows loading on an 8 ft (2,400 mm) trailer
Three-point suspension
Hydraulic front leveling
Front and rear heavy-duty pivots
Solid rubber front tires
Pneumatic rear tires
Telescoping Quick-tach paver attachment
Pintle hook with telescoping pull hitch
Removable elevator rear-discharge hood
Engine instrumentation at ground level
Operator controls on both sides

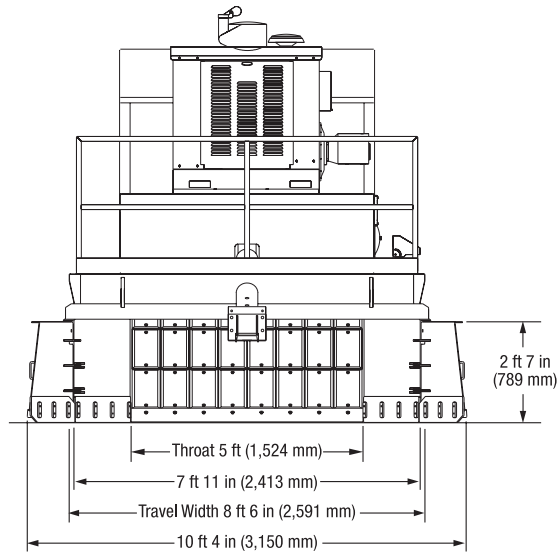
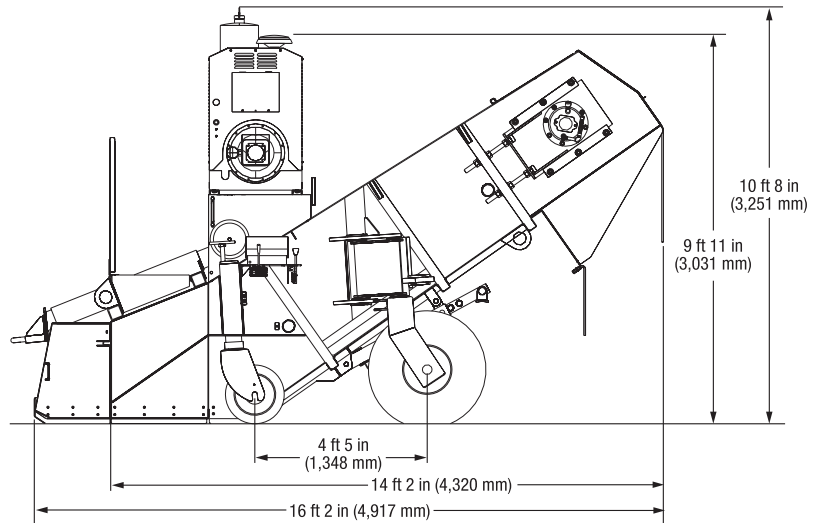

### Pickup Machine

Weight	14,500 lb (6,577 kg)
Capacity (max theoretical)	1,320 TPH (1,199 t/hr)

### Engine

Make	Cummins®
Type	Diesel
Model	QSB4.5
Horsepower	121 hp (90 kW) @ 2,200 rpm
Electrical	12 volt
Environmental	Tier 3 compliant

### Tires

Front (2)	18 x 9 in (457 x 229 mm) solid
Rear (2)	8.25 x 15 in (210 x 381 mm) 14-ply

### Elevator

Width	60 in (1,524 mm)
Flight construction	Bolt-on
Flight size	6 x 4 x 0.5 in (152 x 102 x 13 mm)
Roller chain type	B1
Roller chain pitch	5.51 in (140 mm)
High-alloy liners	0.375 in (10 mm)

### Capacities

Diesel fuel	55 gal (208 L)
Hydraulic oil	43 gal (163 L)
Cooling system	7.1 gal (27 L)

### Optional Equipment

Diesel spray-down hose reel
Lower hopper insert for paver
Radio remote control

Effective Date: December 2008. Product specifications and prices are subject to change without notice or obligation. The photographs and/or drawings in this document are for illustrative purposes only. Refer to the appropriate Operator's Manual for instructions on the proper use of this equipment. Failure to follow the appropriate Operator's Manual when using our equipment or to otherwise act irresponsibly may result in serious injury or death. The only warranty applicable to our equipment is the standard written warranty applicable to the particular product and sale and Terex makes no other warranty, express or implied. Products and services listed may be trademarks, service marks or trade names of Terex Corporation and/or its subsidiaries in the USA and other countries. All rights are reserved. Terex is a registered trademark of Terex Corporation in the USA and many other countries. Copyright 2008 Terex Corporation.

Terex Roadbuilding  
P.O. Box 1985, Oklahoma City, OK 73101  
(405) 787.6020 1-888-TEREXRB  
www.terexrb.com

